



















CONTENTS

SECTION	TITLE	PAGE
Castor and Wheel Guide	Mountings	1
	Castor configurations	2-3
	Hard Tread Wheels	4
	Soft Tread Wheels	5-6
	Wheel Bearings	7

RANGE	PRODUCT	PHOTO	DETAILS		PAGE
			Wheel dia. (mm)	Load capacity (kg)	
Economy Range	Nylon		50-75	40-55	8
Economy Range	Nylon		50-75	40-100	9
Twin Wheel Light Duty/ Institutional Range	Polypropylene		50-75	55-80	10-11
Twin Wheel Light Duty/ Institutional Range	Nylon		50-75	60-100	12-13
Twin Wheel Light Duty/ Institutional Range	PVC tyre		50-75	55-80	14-15
Economy Range	Rubber tyre		50-100	40-70	16
Light Duty/ Institutional Range	Polypropylene		75-125	70-125	17
Light Duty/ Institutional Range	Thermoplastic rubber		75-100	75-100	18
Light Duty/ Institutional Range	Thermoplastic rubber		100-125	100	19
Tubular Fitting Expanders & Buffers					20
Light Duty/ Institutional Range	Thermoplastic rubber		75-125	75-100	21
Medium Duty Pressed Steel	Solid rubber tyre, Polypropylene centre		80-125	60-100	22
Medium Duty Pressed Steel	Solid rubber tyre, Polypropylene centre		160-200	135-205	23
Medium Duty Pressed Steel	Solid rubber tyre, Metal centre		80-200	60-205	24
Medium Duty Pressed Steel	Elastic rubber tyre, Nylon centre		80-200	150-400	25
Medium Duty Pressed Steel	Elastic rubber tyre, Nylon centre		80-125	150-200	26

CONTENTS













RANGE	PRODUCT	PHOTO	DETAILS		PAGE
			Wheel dia. (mm)	Load capacity (kg)	
Tubular Fitting	Expanders and solid steel stems				27
Medium Duty Pressed Steel	Elastic rubber tyre, Aluminium centre		100-125	200	28
Medium Duty Pressed Steel	Elastic rubber tyre, Aluminium centre		160-200	350-400	29
Medium Duty Pressed Steel	Polyurethane tyre, Nylon centre		80-125	100-200	30
Medium Duty Pressed Steel	Polyurethane tyre, Nylon centre		150-200	350-400	31
Medium Duty Pressed Steel	Nylon		80-200	170-400	32
Medium Duty Pressed Steel	Nylon		100-200	200-400	33
Heavy Duty Pressed Steel	Elastic rubber tyre, Nylon centre		100-125	200	34
Heavy Duty Pressed Steel	Elastic rubber tyre, Nylon centre		160-200	350-400	35
Heavy Duty Pressed Steel	Elastic rubber tyre, Aluminium centre		100-125	200-250	36
Heavy Duty Pressed Steel	Elastic rubber tyre, Aluminium centre		160-200	350-450	37
Heavy Duty Pressed Steel	Elastic rubber tyre, Cast iron centre		150-200	400-600	38
Heavy Duty Pressed Steel	Polyurethane tyre, Nylon centre		100-125	220-300	39
Heavy Duty Pressed Steel	Polyurethane tyre, Nylon centre		150-200	350-400	40
Heavy Duty Pressed Steel	Polyurethane tyre, Nylon centre		160-200	600	41
Heavy Duty Pressed Steel	Polyurethane tyre, Aluminium centre		100-125	225-275	42
Heavy Duty Pressed Steel	Polyurethane tyre, Aluminium centre		160-200	600	43
Heavy Duty Pressed Steel	Polyurethane tyre, Cast iron centre		100-125	250-300	44
Heavy Duty Pressed Steel	Polyurethane tyre, Cast iron centre		150-200	600	45
Heavy Duty Pressed Steel	Nylon		100-125	250-300	46
Heavy Duty Pressed Steel	Nylon		160-200	400-600	47

CONTENTS

RANGE	PRODUCT	PHOTO	DETAILS		PAGE
			Wheel dia. (mm)	Load capacity (kg)	
Heavy Duty Pressed Steel	Nylon		160-200	600	48
Heavy Duty Pressed Steel Towable	Elastic rubber tyre, Aluminium centre		160-250	350-650	49
Heavy Duty Pressed Steel Towable	Elastic rubber tyre, Aluminium centre		160-200	350-450	50
Heavy Duty Pressed Steel Towable	Rubber tyre, Cast iron centre		150-250	400-700	51
Heavy Duty Pressed Steel Towable	Polyurethane Tyre, Nylon centre		160-200	650-800	52
Heavy Duty Pressed Steel Towable	Polyurethane Tyre, Aluminium centre		160-200	600-800	53
Heavy Duty Pressed Steel Towable	Polyurethane tyre, Cast iron centre		150-250	800-1000	54
Heavy Duty Pressed Steel Towable	Polyurethane Crown Turned Tyre, Cast iron		150-200	650-800	55
Heavy Duty Pressed Steel Towable	Nylon		160-200	900-1000	56
Heavy Duty Fabricated Steel	Nylon		100-200	250-600	57
Extra Heavy Duty Fabricated Steel Towable	Elastic rubber tyre, Aluminium centre		160-200	350-450	58
Extra Heavy Duty Fabricated Steel Towable	Elastic rubber tyre, Aluminium centre		160-200	350-450	59
Extra Heavy Duty Fabricated Steel Towable	Elastic rubber tyre, Cast iron centre		150-200	400-600	60
Extra Heavy Duty Fabricated Steel Towable	Polyurethane Tyre, Nylon centre		160-200	650-800	61
Extra Heavy Duty Fabricated Steel Towable	Polyurethane tyre, Cast iron centre		150-200	800-1000	62
Extra Heavy Duty Fabricated Steel Towable	Polyurethane Crown Turned Tyre, Cast iron		150-200	650-800	63
Extra Heavy Duty Fabricated Steel Towable	Nylon		160-200	900-1200	64
Extra Heavy Duty Fabricated Steel Towable	Cast Iron		150-200	900-1100	65
Twin Heavy Duty Fabricated Steel Towable	Nylon & Polyurethane tyred		150-200	1000-1500	66
Twin Heavy Duty Fabricated Steel Towable	Rubber tyre, Cast iron centre & Cast iron		150-200	800-1500	67
Twin Heavy Duty Fabricated Steel Towable	Polyurethane tyre, Cast iron centre		150-200	1500	68







RANGE	PRODUCT	PHOTO	DETAILS		PAGE
			Wheel dia. (mm)	Load capacity (kg)	
Twin Extra Heavy Duty Fabricated Steel Towable	Nylon		150-250	2000	69
Twin Extra Heavy Duty Fabricated Steel Towable	Polyurethane tyre, Cast iron centre & Cast iron		150-250	1600-2000	70
Truck Locks	Pressed Steel, Zinc plated Cast Iron, Black paint finish				71

SPECIALIST CASTORS

Medium Duty Pressed Stainless Steel	304 Grade Stainless Steel		80-200	100-400	74
Heavy Duty Pressed Stainless Steel	304 Grade Stainless Steel		80-200	170-450	75
Light Duty Pressed Steel	Anti Static 		50-125	40-100	76-77
Medium Duty Pressed Steel	Anti Static 		100-125	125	78-79
Heavy Duty Pressed Steel	Anti Static 		80-200	130-400	80-81
Plastic Castors			100-200	100-120	82
High Temperature Castors	Phenolic 		100	125	83
Heavy Duty Pressed Steel	Composite/ Sandwich		100	200	84
Heavy Duty Pressed Steel	Composite/ Sandwich		125	200	85
Medium Duty Pressed Steel	Microcellular		260	120	86-89

WHEELS

Rubber Tyred Wheels		80-200	60-205	91
Rubber Tyred Wheels		75-200	75-400	92
Rubber Tyred Wheels		100-300	200-800	93
Polyurethane Tyred Wheels		80-200	100-800	94
Polyurethane Tyred Wheels		100-300	225-2200	95
Polypropylene & Nylon Wheels		75-200	70-1200	96

RANGE	PRODUCT	PHOTO	DETAILS		PAGE
			Wheel dia. (mm)	Load capacity (kg)	
Cast Iron, Phenolic & Anti-Static Wheels			100-250	125-1500	97
Microcellular Wheels			260	120	98
Manutal Range	Solid black rubber tyre, Plastic centre		160-300	175-250	99
Industrial Wheel	Solid black rubber tyre, Plastic centre		200	250	100
Industrial Wheel	Solid black rubber tyre, Plastic centre		280-400	250-350	101
Industrial Wheel	Solid black rubber tyre, Metal centre		280-330	250-300	102
Industrial Wheel	Solid black rubber tyre, Metal centre		355-400	400	103
NOTES	Space to write your own notes				104-106

Castor and Wheel Guide

MOUNTINGS

Top Plate

The most common fixing with four boltholes to spread the load over the swivel head.

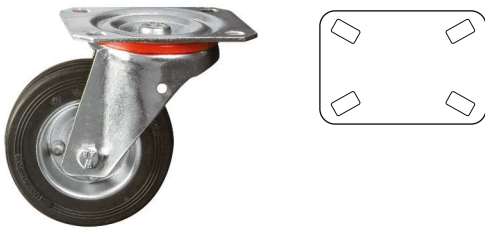

Single Bolthole

Limited to loads of up to 400kg. Designed to be mounted with a fastener through the centre of the swivel head. This style of castor can be fitted with expanders, solid steel stems, threaded stems, loose bolts etc.



Loadings

This is calculated from the gross weight of the load and equipment. Special allowance should be made in the event of uneven distribution of weight, this can result in one wheel/castor carrying more load than the rest. Power towing can also contribute to severe shock loading.

Floor Conditions

Rough and uneven floors can also contribute to severe overloading. If one wheel/castor leaves the floor, the remaining castors have to absorb the load.

Castor and Wheel Guide

CASTOR CONFIGURATIONS

2 Swivel Castors and 2 Fixed Castors

Providing good load capacity and manoeuvrability, this combination ensures accurate steering, even on long straight runs, making it the most practical combination for industrial use. Any trolley with this castor combination should be pushed with the fixed castors leading.

Maximum capacity for each wheel = $\text{load}/3$



4 Swivel Castors

As this combination gives good load capacity with exceptional manoeuvrability, it is suitable for winding runs and where sideways action is required. It is not recommended for straight runs or ramps, as it may be hard to guide, especially over bumpy terrain and when heavily loaded. However, equipping two castors with directional locks makes this arrangement very versatile and suitable for long straight runs.

Maximum capacity for each wheel = $\text{load}/3$

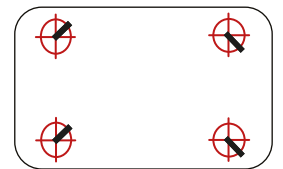

1 Swivel Castor and 2 Fixed Castors

This combination provides an economical solution for lightly loaded trolleys requiring good manoeuvrability. The trolley must be reasonably small in size and load must be evenly distributed to ensure stability.

Maximum capacity for each wheel = $\text{load}/2.5$

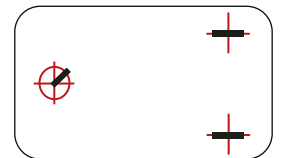

3 Swivel Castors

This provides good load capacity with excellent manoeuvrability. However, equipment with this arrangement will be difficult to guide on straight runs particularly over uneven ground.

Maximum capacity for each wheel = $\text{load}/2.5$

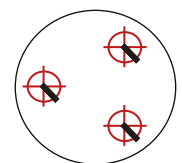

Castor and Wheel Guide

4 Swivel Castors and 2 Fixed Castors (centrally pivoting)

This combination provides an extremely high load capacity, with great manoeuvrability and stability. This is ideal for very long trolleys designed to carry heavy loads - the fixed castors can be replaced by wheels mounted onto a central axle.

The unit's base must be robust and the swivel castors are mounted to allow the trolley to pivot on the central wheels. Therefore, 25mm of packing is required above the two fixed castors (wheels) to give alternating load support, depending on which pair of wheels is in contact with the floor. The entire load rests on 2 central, fixed castors/wheels.

PLEASE NOTE: The swivel castors are subjected to shock loads if the trolley is tipped or the load is not evenly distributed.

Maximum capacity for each wheel = load/2

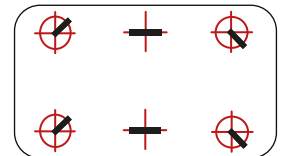

2 Swivel Castors and 2 Fixed Castors

Ideal for confined spaces, this configuration provides good load capacity with excellent manoeuvrability. The fixed castor can be replaced by wheels which pivot the trolley centrally. In this case, 25mm of the packing is necessary above the two fixed castors (wheels) to give alternating load support. However, if the trolley is tipped or the load is not evenly distributed, the swivel castors are subjected to shock loads. The entire load rests on the 2 central, fixed castors/wheels.

Maximum capacity for each wheel = load/2

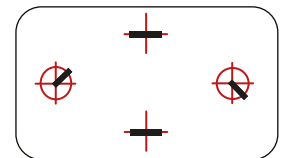

Castor and Wheel Guide – Wheel Types

HARD TREAD WHEELS

Hard Tread Wheels are the easiest to push as they have least tractive resistance. The main disadvantage is that they are noisy and can wear floors excessively. The main types of hard wheels are as follows:

Cast Iron and Steel

Cast Iron and Steel wheels combine shock resistance with long life.

Temperature range: -40°C to $+300^{\circ}\text{C}$



Nylon

Nylon has high load capacity, is light and clean and causes little floor damage.

Temperature range: -40°C to $+80^{\circ}\text{C}$



Polypropylene

Polypropylene has good load capacity but not the abrasion or fracture resistance of nylon.

Operational temperature range: -20°C to $+80^{\circ}\text{C}$



Phenolic

Phenolic is very hard, abrasion and fracture resistant but liable to wear and chipping.

High operational temperature range: up to $+350^{\circ}\text{C}$



Castor and Wheel Guide – Wheel Types

SOFT TREAD WHEELS

Soft Tread Wheels are resilient, generally resulting in less noise, marking and floor wear. Tractive resistance is higher than hard tread wheels. New development grades of polyurethane and rubber have increased load capacities while reducing tractive resistance.

Solid Rubber

Solid Rubber, medium load capacity, smooth cushioned ride, economical.

Temperature range: -20°C to +60°C



PVC

PVC tread for light duty applications.

Temperature range: -10°C to +60°C



Thermoplastic Rubber

Thermoplastic Rubber, medium load capacity, harder wearing than standard solid rubber.

Temperature range: -20°C to +60°C



Elastic Rubber

Elastic Rubber has a high load capacity and wear resistance with a smooth soft-cushioned ride.

Temperature range: -20°C to +60°C



Polyurethane

Polyurethane has a very high load capacity with abrasion, tear and chemical resistance and a soft ride.

Temperature range: -30°C to +90°C



Castor and Wheel Guide – Wheel Types

SOFT TREAD WHEELS

Anti-Static

Anti-static Non-marking material. Has a high load capacity with abrasion, tear and chemical resistance and a soft ride. The wheels we supply have an electrical resistance of less than 10^4 ohm. Each individual wheel is subjected to electrical testing.

Temperature range: -20°C to $+70^{\circ}\text{C}$



Pneumatic

Pneumatic has excellent shock absorption working well on rough, uneven surface like gravel or grass.

Temperature range: -20°C to $+60^{\circ}\text{C}$



Microcellular

Microcellular wheel behaves in a similar way to a pneumatic wheel, but has a microcellular infill which allows the wheel to keep its bounce without the risk of puncturing.

Temperature range: -20°C to $+60^{\circ}\text{C}$



Castor and Wheel Guide

WHEEL BEARINGS

The three types of wheel bearings used are shown below:

Plain Bore

Consists of an axle hole machined or moulded in the wheel centre. The centre is usually of cast iron or nylon material. Suitable for light loads or where low rolling friction is not important.

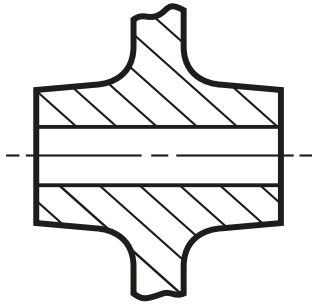

Roller Bearing

The most popular low cost easy movement bearing. Widely used to reduce the manual effort to move heavy loads. This type of bearing needs no adjustment on the axle.

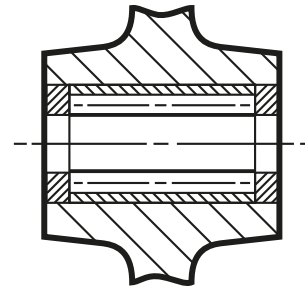

Ball Bearing

Precision bearings with a spacer in between. Gives very low friction. Shielded to retain the grease and exclude grit. Inner bearing races need to be clamped endwise on assembly.

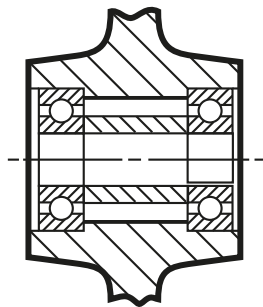

Economy Range: Nylon

50mm - 75mm diameter wheel | 40kg - 55kg load capacity



- Pressed steel bracket, zinc plated
- Swivel head with double ball race
- White nylon wheel
- Plain bearing
- Wheel brake

Bolt hole fitting

Wheel Dia. (mm)	Tread Width (mm)	Overall Height (mm)	Bolt hole Dia. (mm)	Load Capacity (kg)	SWIVEL Part number	BRAKED Part number
50	20	69	10	40	RT2EBHNY	RT2EBHBNY
75	25	97	10	55	RT3EBHNY	RT3EBHBNY

Plate fitting

Wheel Dia. (mm)	Tread Width (mm)	Overall Height (mm)	Plate Size (mm)	Hole Centres (mm)	Load Capacity (kg)	SWIVEL Part number	BRAKED Part number
50	20	74	50 x 50	38 x 38	40	RT2EPNY	RT2EPBNY
75	25	103	65 x 65	47 x 47	55	RT3EPNY	RT3EPBNY

Economy Range: Nylon

50mm - 75mm diameter wheel | 40kg - 100kg load capacity



- Pressed steel bracket, zinc plated
- Swivel head with single ball race
- White nylon wheel
- Plain bearing

Plate fitting

Wheel Dia. (mm)	Tread Width (mm)	Overall Height (mm)	SWIVEL Plate Size (mm)	SWIVEL Hole Centres (mm)	FIXED Plate Size (mm)	FIXED Hole Centres (mm)	Load Capacity (kg)	SWIVEL Part no.	FIXED Part no.
50	25	64	65 x 47	54 x 24			40	RT2PNY	N/A
50	25	64			66 x 42	54 x 24	40	N/A	RT2FNY
63	28	81	94 x 70	76 x 44.5			85	RT25PNY	N/A
63	28	81			98 x 54	81 x 25	85	N/A	RT25FNY
75	30	95	105 x 80	80 x 60			100	RT3PNY	N/A
75	30	95			102 x 60	83 x 35	100	N/A	RT3FNY

Twin Wheel Light Duty/ Institutional Range: Polypropylene

50mm - 75mm diameter wheel | 55kg - 80kg load capacity



- Pressed steel bracket, zinc plated
- Swivel head with double ball race
- Black polypropylene wheel
- Plain bearing
- Wheel brake

Bolt hole fitting

Wheel Dia. (mm)	Tread Width (mm)	Overall Height (mm)	Bolt hole Dia. (mm)	Load Capacity (kg)	SWIVEL Part number	BRAKED Part number
50	42	69	10	55	RT2TWBHPP	RT2TWBHBPP
75	52	98	10	80	RT3TWBHPP	RT3TWBHBPP

Twin Wheel Light Duty/ Institutional Range: Polypropylene

50mm - 75mm diameter wheel | 55kg - 80kg load capacity



- Pressed steel bracket, zinc plated
- Swivel head with double ball race
- Black polypropylene wheel
- Plain bearing
- Wheel brake

Plate fitting

Wheel Dia. (mm)	Tread Width (mm)	Overall Height (mm)	Plate Size (mm)	Hole Centres (mm)	Load Capacity (kg)	SWIVEL Part number	BRAKED Part number
50	42	77	65 x 65	47 x 47	55	RT2TWPPP	RT2TWPBPP
75	52	101	78 x 68	$\frac{60 \times 50}{50 \times 43}$	80	RT3TWPPP	RT3TWPBPP

75mm castor mounting plates have slotted hole centres.

Twin Wheel Light Duty/ Institutional Range: Nylon

50mm - 75mm diameter wheel | 60kg - 100kg load capacity



- Pressed steel bracket, zinc plated
- Swivel head with double ball race
- White nylon wheel
- Plain bearing
- Wheel brake

Bolt hole fitting

Wheel Dia. (mm)	Tread Width (mm)	Overall Height (mm)	Bolt hole Dia. (mm)	Load Capacity (kg)	SWIVEL Part number	BRAKED Part number
50	42	69	10	60	RT2TWBHNHNY	RT2TWBHBHNY
75	52	98	10	100	RT3TWBHNHNY	RT3TWBHBHNY

Twin Wheel Light Duty/ Institutional Range: Nylon

50mm - 75mm diameter wheel | 60kg - 100kg load capacity



- Pressed steel bracket, zinc plated
- Swivel head with double ball race
- White nylon wheel
- Plain bearing
- Wheel brake

Plate fitting

Wheel Dia. (mm)	Tread Width (mm)	Overall Height (mm)	Plate Size (mm)	Hole Centres (mm)	Load Capacity (kg)	SWIVEL Part number	BRAKED Part number
50	42	77	65 x 65	47 x 47	60	RT2TWPNY	RT2TWPBNY
75	52	101	78 x 68	$\frac{60 \times 50}{50 \times 43}$	100	RT3TWPNY	RT3TWPBNY

75mm castor mounting plates have slotted hole centres.

Twin Wheel Light Duty/ Institutional Range: PVC tyre

50mm - 75mm diameter wheel | 55kg - 80kg load capacity



- Pressed steel bracket, zinc plated
- Swivel head with double ball race
- Grey PVC tyre, white nylon centre wheel
- Plain bearing
- Wheel brake

Bolt hole fitting

Wheel Dia. (mm)	Tread Width (mm)	Overall Height (mm)	Bolt hole Dia. (mm)	Load Capacity (kg)	SWIVEL Part number	BRAKED Part number
50	42	69	10	55	RT2TWBHGREY	RT2TWBHBGREY
75	52	98	10	80	RT3TWBHGREY	RT3TWBHBGREY

Twin Wheel Light Duty/ Institutional Range: PVC tyre

50mm - 75mm diameter wheel | 55kg - 80kg load capacity



- Pressed steel bracket, zinc plated
- Swivel head with double ball race
- Grey PVC tyre, white nylon centre wheel
- Plain bearing
- Wheel brake

Plate fitting

Wheel Dia. (mm)	Tread Width (mm)	Overall Height (mm)	Plate Size (mm)	Hole Centres (mm)	Load Capacity (kg)	SWIVEL Part number	BRAKED Part number
50	42	77	65 x 65	47 x 47	55	RT2TWPGREY	RT2TWPBGREY
75	52	101	78 x 68	$\frac{60 \times 50}{50 \times 43}$	80	RT3TWPGREY	RT3TWPBGREY

75mm castor mounting plates have slotted hole centres.

Economy Range: Rubber tyre

50mm - 100mm diameter wheel | 40kg - 70kg load capacity



- Pressed steel bracket, zinc plated
- Swivel head with double ball race
- Grey rubber tyre, grey polypropylene centre wheel
- Plain bearing, complete with zinc plated metal threadguards
- Wheel brake available on 50mm and 75mm
- Swivel and wheel brake available on 100mm

Bolt hole fitting

Wheel Dia. (mm)	Tread Width (mm)	Overall Height (mm)	Bolt Hole Dia. (mm)	Load Capacity (kg)	SWIVEL Part number	BRAKED Part number
50	15	70	M10	40	RT2BHGREY	RT2BHBGREY
75	20	101	M10	60	RT3BHGREY	RT3BHBGREY
100	25	132	M10	70	RT4BHGREY	RT4BHBGREY
100	25	132	M12	70	RT4BHGREY/M12	RT4BHBGREY/M12

Plate fitting

Wheel Dia. (mm)	Tread Width (mm)	Overall Height (mm)	Plate Size (mm)	Hole Centres (mm)	Load Capacity (kg)	SWIVEL Part number	BRAKED Part number
50	15	72	50 x 50	$\frac{38 \times 38}{34 \times 34}$	40	RT2PGREY	RT2PBGREY
75	20	103	65 x 65	$\frac{53 \times 53}{45 \times 45}$	60	RT3PGREY	RT3PBGREY
100	25	134	75 x 75	$\frac{60 \times 60}{50 \times 50}$	70	RT4PGREY	RT4PBGREY



Optional Extra

Tubular Fittings

Light Duty/ Institutional Range: Polypropylene

75mm - 125mm diameter wheel | 70kg - 125kg load capacity



- Pressed steel bracket, zinc plated
- Swivel head with double ball race
- White polypropylene wheel
- Plain bore
- Combined swivel and wheel brake

Bolt hole fitting

Wheel Dia. (mm)	Tread Width (mm)	Overall Height (mm)	Bolt Hole Dia. (mm)	Load Capacity (kg)	SWIVEL Part number	BRAKED Part number
75	25	100	M12	70	RT3A-BHPP	RT3A-BHBPP
100	32	134	M12	125	RT4A-BHPP	RT4A-BHBPP
125	35	159	M12	125	RT5A-BHPP	RT5A-BHBPP



Tubular Fittings



M12-M10 Reducer



Wheel Options

Light Duty/ Institutional Range: Thermoplastic rubber tyre

75mm - 100mm diameter wheel | 75kg - 100kg load capacity



- Pressed steel bracket, zinc plated
- Swivel head with double ball race
- Grey thermoplastic rubber tyre, grey polypropylene centre wheel
- Plain bore, complete with zinc plated metal threadguards
- Combined swivel and wheel brake

Bolt hole fitting

Wheel Dia. (mm)	Tread Width (mm)	Overall Height (mm)	Bolt Hole Dia. (mm)	Load Capacity (kg)	SWIVEL Part number	BRAKED Part number
75	32	100	M12	75	RT3A-BHGREY-PB/TG	RT3A-BHBGREY-PB/TG
100	32	134	M12	100	RT4A-BHGREY-PB/TG	RT4A-BHBGREY-PB/TG



Tubular Fittings



M12-M10 Reducer



Wheel Options

Light Duty/ Institutional Range: Thermoplastic rubber tyre

100mm - 125mm diameter wheel | 100kg load capacity



- Pressed steel bracket, zinc plated
- Swivel head with double ball race
- Grey thermoplastic rubber tyre, grey polypropylene centre wheel
- Ball bearing, complete with grey plastic threadguards
- Combined swivel and wheel brake



Bolt hole fitting

Wheel Dia. (mm)	Tread Width (mm)	Overall Height (mm)	Bolt Hole Dia. (mm)	Load Capacity (kg)	SWIVEL Part number	BRAKED Part number
100	32	134	M12	100	RT4A-BHGREY	RT4A-BHBGREY
125	32	159	M12	100	RT5A-BHGREY	RT5A-BHBGREY



Tubular Fittings



M12-M10 Reducer



Wheel Options

Tubular Fitting: Expanders and Buffers

Suitable for use with our range of: Economy, Light Duty and Medium Duty castors



Expanders

ROUND EXPANDER Part number	TO FIT TUBE Internal dimensions (mm)
EXPRD19	19-21.5
EXPRD22	21.5-24
EXPRD24	24-27
EXPRD27	27-30
EXPRD31	31-35
EXPRD36	36-40

SQUARE EXPANDER Part number	TO FIT TUBE Internal dimensions (mm)
EXPSQ22	21.5-24
EXPSQ24	24-27
EXPSQ27	27-30
EXPSQ32	32-35
EXPSQ36	36-40

NB: Suffix CP= Cap Head Bolt, Suffix HX= Hexagon Head Bolt. We recommend Cap Head Bolts are used on 50mm and 75mm castors.

Buffers

- Grey Plastic Buffer
- Shore hardness: Sh/A 60

ROUND CENTRE BORE Part number	A (mm)	B (mm)	C (mm)	D (mm)
D1-20	90	20.5	20	50
D1-22	90	22	20	50
D1-25	90	25.5	20	50
D1-32	90	32	20	50

SQUARE CENTRE BORE Part number	A (mm)	B (mm)	C (mm)	D (mm)
D1-20Q	90	20	20	50
D1-25Q	90	25	20	50

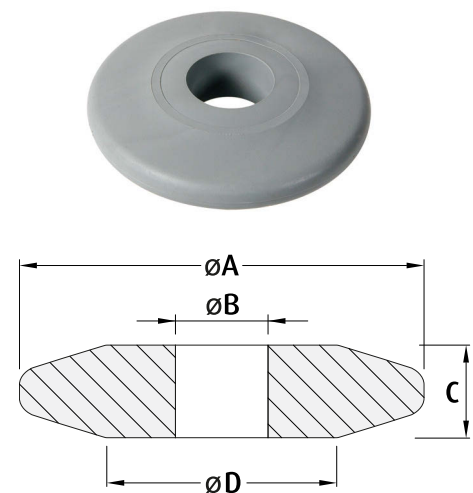

Light Duty/ Institutional Range: Thermoplastic rubber tyre

75mm - 125mm diameter wheel | 75kg - 100kg load capacity



- Pressed steel bracket, zinc plated
- Swivel head with double ball race
- Grey thermoplastic rubber tyre, grey polypropylene centre wheel
- Plain bore, complete with zinc plated metal threadguards
- Combined swivel and wheel brake

Plate fitting

Wheel Dia. (mm)	Tread Width (mm)	Overall Height (mm)	Plate Size (mm)	Hole Centres (mm)	Load Capacity (kg)	SWIVEL Part number	BRAKED Part number
75	32	103	105x80	$\frac{80 \times 60}{76 \times 44.5}$	75	RT3A-PGREY-PB/TG	RT3A-PBGREY-PB/TG
100	32	137	105 x 80	$\frac{80 \times 60}{76 \times 44.5}$	100	RT4A-PGREY-PB/TG	RT4A-PBGREY-PB/TG
125	32	162	105 x 80	$\frac{80 \times 60}{76 \times 44.5}$	100	RT5A-PGREY-PB/TG	RT5A-PBGREY-PB/TG

Castor mounting plates have slotted hole centres.



Wheel Options

Medium Duty Pressed Steel: Solid rubber tyre | Polypropylene centre

80mm - 125mm diameter wheel | 60kg - 100kg load capacity



- Pressed steel bracket, zinc plated
- Swivel head with double ball race
- Black solid rubber tyre, black polypropylene centre wheel
- Roller bearing
- Combined swivel and wheel brake



Bolt hole fitting

Wheel Diameter (mm)	Tread Width (mm)	Overall Height (mm)	Bolt Hole Diameter (mm)	Load Capacity (kg)	SWIVEL Part number	BRAKED Part number
80	31/22	99	M12	60	RT3LBH-BP	RT3LBHB-BP
100	31/24	124	M12	75	RT4LBH-BP	RT4LBHB-BP
125	38/25	154	M12	100	RT5LBH-BP	RT5LBHB-BP

Plate fitting

Wheel Dia. (mm)	Tread Width (mm)	Overall Height (mm)	Plate Size (mm)	Hole Centres (mm)	Load Capacity (kg)	SWIVEL Part number	BRAKED Part number	FIXED Part number
80	31/22	100	105 X 80	80 X 60	60	RT3LP-BP	RT3LPB-BP	RT3LFP-BP
100	31/24	125	105 X 80	80 X 60	75	RT4LP-BP	RT4LPB-BP	RT4LFP-BP
125	38/25	155	105 X 80	80 X 60	100	RT5LP-BP	RT5LPB-BP	RT5LFP-BP



Tubular Fittings



Thread Guards



M12-M10 Reducer



Grey Rubber Tyre

Medium Duty Pressed Steel: Solid rubber tyre | Polypropylene centre

160mm - 200mm diameter wheel | 135kg - 205kg load capacity



- Pressed steel bracket, zinc plated
- Swivel head with double ball race
- Black solid rubber tyre, red polypropylene centre wheel
- Roller bearing
- Combined swivel and wheel brake



Bolt hole fitting

Wheel Dia. (mm)	Tread Width (mm)	Overall Height (mm)	Bolt Hole Dia. (mm)	Load Capacity (kg)	SWIVEL Part number	BRAKED Part number
160	41/21	185	M16	135	RT6LBH-BP	RT6LBHB-BP
200	48/30	230	M16	205	RT8LBH-BP	RT8LBHB-BP

Plate fitting

Wheel Dia. (mm)	Tread Width (mm)	Overall Height (mm)	Plate Size (mm)	Hole Centres (mm)	Load Capacity (kg)	SWIVEL Part number	BRAKED Part number	FIXED Part number
160	41/21	190	135 X 110	105 X 80	135	RT6LP-BP	RT6LPB-BP	RT6LFP-BP
200	48/30	235	135 X 110	105 X 80	205	RT8LP-BP	RT8LPB-BP	RT8LFP-BP



Tubular Fittings



Thread Guards



M12-M10 Reducer
M16-M12 Reducer



Grey Rubber Tyre



Directional Lock for
Plate Fitting Castors

Medium Duty Pressed Steel: Solid rubber tyre | Metal centre

80mm - 200mm diameter wheel | 60kg - 205kg load capacity



- Pressed steel bracket, zinc plated
- Swivel head with double ball race
- Black solid rubber tyre, pressed steel zinc plated centre wheel
- Roller bearing
- Combined swivel and wheel brake



Bolt hole fitting

Wheel Dia. (mm)	Tread Width (mm)	Overall Height (mm)	Bolt Hole Dia. (mm)	Load Capacity (kg)	SWIVEL Part number	BRAKED Part number
80	28/20	99	M12	60	RT3LBH-BM	RT3LBHB-BM
100	30/21	124	M12	75	RT4LBH-BM	RT4LBHB-BM
125	36/25	154	M12	100	RT5LBH-BM	RT5LBHB-BM
160	38/25	185	M16	135	RT6LBH-BM	RT6LBHB-BM
200	45/30	230	M16	205	RT8LBH-BM	RT8LBHB-BM

Plate fitting

Wheel Dia. (mm)	Tread Width (mm)	Overall Height (mm)	Plate Size (mm)	Hole Centres (mm)	Load Capacity (kg)	SWIVEL Part number	BRAKED Part number	FIXED Part number
80	28/20	100	105 X 80	80 X 60	60	RT3LP-BM	RT3LPB-BM	RT3LFP-BM
100	30/21	125	105 X 80	80 X 60	75	RT4LP-BM	RT4LPB-BM	RT4LFP-BM
125	36/25	155	105 X 80	80 X 60	100	RT5LP-BM	RT5LPB-BM	RT5LFP-BM
160	38/25	190	135 X 110	105 X 80	135	RT6LP-BM	RT6LPB-BM	RT6LFP-BM
200	45/30	235	135 X 110	105 X 80	205	RT8LP-BM	RT8LPB-BM	RT8LFP-BM



Tubular Fittings



Thread Guards



M12-M10 Reducer
M16-M12 Reducer



Grey Rubber Tyre



Directional Lock
Available on 160 and 200mm castors. Plate fitting only.

Medium Duty Pressed Steel: Elastic rubber tyre | Nylon centre

80mm - 200mm diameter wheel | 150kg - 400kg load capacity



- Pressed steel bracket, zinc plated
- Swivel head with double ball race
- Blue elastic rubber tyre, black nylon centre wheel
- Roller bearing
- Combined swivel and wheel brake
- Blue plastic threadguards supplied with 100mm castors
- Zinc plated metal threadguards supplied with 125mm and 160mm castors



Bolt hole fitting

Wheel Dia. (mm)	Tread Width (mm)	Overall Height (mm)	Bolt Hole Dia. (mm)	Load Capacity (kg)	SWIVEL Part number	BRAKED Part number
80	34/23	99	M12	150	RT3LBHBLU	RT3LBHBBLU
100	35/25	124	M12	200	RT4LBHBLU	RT4LBHBBLU
125	35/25	154	M12	200	RT5LBHBLU	RT5LBHBBLU
160	45/41	185	M16	350	RT6LBHBLU	RT6LBHBBLU
200	45/38	230	M16	400	RT8LBHBLU	RT8LBHBBLU

Plate fitting

Wheel Dia. (mm)	Tread Width (mm)	Overall Height (mm)	Plate Size (mm)	Hole Centres (mm)	Load Capacity (kg)	SWIVEL Part number	BRAKED Part number	FIXED Part number
80	34/23	100	105 X 80	80 X 60	150	RT3LPBLU	RT3LPBBLU	RT3LFPBLU
100	35/25	125	105 X 80	80 X 60	200	RT4LPBLU	RT4LPBBLU	RT4LFPBLU
125	35/25	155	105 X 80	80 X 60	200	RT5LPBLU	RT5LPBBLU	RT5LFPBLU
160	45/41	190	135 X 110	105 X 80	350	RT6LPBLU	RT6LPBBLU	RT6LFPBLU
200	45/38	235	135 X 110	105 X 80	400	RT8LPBLU	RT8LPBBLU	RT8LFPBLU



Tubular Fittings



M12-M10 Reducer
M16-M12 Reducer



Grey Tyre



Directional Lock
Available on 160 and 200mm castors. Plate fitting only.

Medium Duty Pressed Steel: Elastic rubber tyre | Nylon centre

80mm - 125mm diameter wheel | 150kg - 200kg load capacity



- Pressed steel bracket, zinc plated
- Swivel head with double ball race
- Black elastic rubber tyre, black nylon centre wheel
- Roller bearing
- Combined swivel and wheel brake
- Black plastic threadguards supplied with 100mm castors
- Zinc plated metal threadguards supplied with 125mm castors



Bolt hole fitting

Wheel Dia. (mm)	Tread Width (mm)	Overall Height (mm)	Bolt Hole Dia. (mm)	Load Capacity (kg)	SWIVEL Part number BLACK	BRAKED Part number BLACK
80	34/23	99	M12	150	RT3LBHBLK	RT3LBHBBLK
100	35/25	124	M12	200	RT4LBHBLK	RT4LBHBBLK
125	35/25	154	M12	200	RT5LBHBLK	RT5LBHBBLK

Plate fitting

Wheel Dia. (mm)	Tread Width (mm)	Overall Height (mm)	Plate Size (mm)	Hole Centres (mm)	Load Capacity (kg)	SWIVEL Part number BLACK	BRAKED Part number BLACK	FIXED Part number BLACK
80	34/23	100	105 X 80	80 X 60	150	RT3LPBLK	RT3LPBBLK	RT3LFPBLK
100	35/25	125	105 X 80	80 X 60	200	RT4LPBLK	RT4LPBBLK	RT4LFPBLK
125	35/25	155	105 X 80	80 X 60	200	RT5LPBLK	RT5LPBBLK	RT5LFPBLK



Tubular Fittings



M12-M10 Reducer

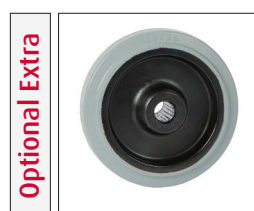

Grey Tyre

Tubular Fitting: Expanders and solid steel stems

Suitable for use with our range of: Economy, Light Duty/ Institutional and Medium Duty castors



Expanders

ROUND EXPANDER Part number	TO FIT TUBE Internal dimensions (mm)
EXPRD19	19-21.5
EXPRD22	21.5-24
EXPRD24	24-27
EXPRD27	27-30
EXPRD31	31-35
EXPRD36	36-40

SQUARE EXPANDER Part number	TO FIT TUBE Internal dimensions (mm)
EXPSQ22	21.5-24
EXPSQ24	24-27
EXPSQ27	27-30
EXPSQ32	32-35
EXPSQ36	36-40

NB: Suffix CP= Cap Head Bolt, Suffix HX= Hexagon Head Bolt. We recommend Cap Head Bolts are used on 50mm and 75mm castors.

Solid steel stems

ROUND STEEL STEM Part number	Ø A (mm)	B (mm)	C	D (mm)
C1	Ø 16.5	45	M8	20
C2	Ø 19	45	M8	20
C3	Ø 20.5	45	M8	20
C4	Ø 21.5	45	M8	20
C5	Ø 22	45	M8	20
C6	Ø 23.5	45	M8	20
C7	Ø 25.5	45	M8	20
C8	Ø 27.5	45	M8	20
C9	Ø 27.8	45	M8	19
C32	Ø 32	45	M6	7

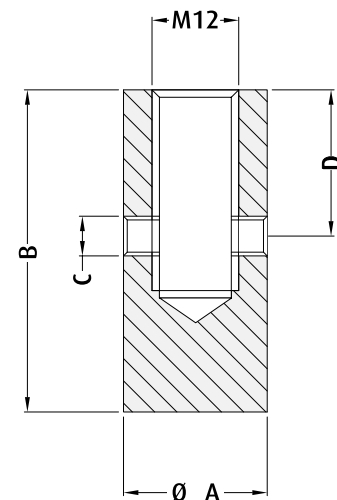

Special size round & square solid stems available (Minimum quantities)

Medium Duty Pressed Steel: Elastic rubber tyre | Aluminium centre

100mm - 125mm diameter wheel | 200kg load capacity



- Pressed steel bracket, zinc plated
- Swivel head with double ball race
- Black elastic rubber tyre, aluminium centre wheel
- Ball bearing
- Combined swivel and wheel brake



Bolt hole fitting

Wheel Dia. (mm)	Tread Width (mm)	Overall Height (mm)	Bolt Hole Dia. (mm)	Load Capacity (kg)	SWIVEL Part number	BRAKED Part number
100	39/29	124	12	200	RT4LBHBLKALU	RT4LBHBBLKALU
125	39/29	154	12	200	RT5LBHBLKALU	RT5LBHBBLKALU

Plate fitting

Wheel Dia. (mm)	Tread Width (mm)	Overall Height (mm)	Plate Size (mm)	Hole Centres (mm)	Load Capacity (kg)	SWIVEL Part number	BRAKED Part number	FIXED Part number
100	39/29	125	105 X 80	80 X 60	200	RT4LPBLKALU	RT4LPBBLKALU	RT4LFPBLKALU
125	39/29	155	105 X 80	80 X 60	200	RT5LPBLKALU	RT5LPBBLKALU	RT5LFPBLKALU



Tubular Fittings



M12-M10 Reducer

Medium Duty Pressed Steel: Elastic rubber tyre | Aluminium centre

160mm - 200mm diameter wheel | 350kg - 400kg load capacity



- Pressed steel bracket, zinc plated
- Swivel head with double ball race
- Black elastic rubber tyre, aluminium centre wheel

- Ball bearing
- Combined swivel and wheel brake



Bolt hole fitting

Wheel Dia. (mm)	Tread Width (mm)	Overall Height (mm)	Bolt Hole Dia. (mm)	Load Capacity (kg)	SWIVEL Part number	BRAKED Part number
160	50/38	185	M16	350	RT6LBHBLKALU	RT6LBHBBLKALU
200	50/38	230	M16	400	RT8LBHBLKALU	RT8LBHBBLKALU

Plate fitting

Wheel Dia. (mm)	Tread Width (mm)	Overall Height (mm)	Plate Size (mm)	Hole Centres (mm)	Load Capacity (kg)	SWIVEL Part number	BRAKED Part number	FIXED Part number
160	50/38	190	135 X 110	105 X 80	350	RT6LPBLKALU	RT6LPBBLKALU	RT6LFPBLKALU
200	50/38	235	135 X 110	105 X 80	400	RT8LPBLKALU	RT8LPBBLKALU	RT8LFPBLKALU



Tubular Fittings



M12-M10 Reducer
M16-M12 Reducer



Grey Tyre



Directional Lock
Plate fitting only

Medium Duty Pressed Steel: Polyurethane tyre | Nylon centre

80mm - 125mm diameter wheel | 100kg - 200kg load capacity



- Pressed steel bracket, zinc plated
- Swivel head with double ball race
- Red polyurethane tyre, white nylon centre wheel
- Roller bearing
- Combined swivel and wheel brake



Bolt hole fitting

Wheel Dia. (mm)	Tread Width (mm)	Overall Height (mm)	Bolt Hole Dia. (mm)	Load Capacity (kg)	SWIVEL Part number	BRAKED Part number
80	30	99	M12	100	RT3LBHPU-RB	RT3LBHBPU-RB
100	35	124	M12	200	RT4LBHPU-RB	RT4LBHBPU-RB
125	35	154	M12	200	RT5LBHPU-RB	RT5LBHBPU-RB

Plate fitting

Wheel Dia. (mm)	Tread Width (mm)	Overall Height (mm)	Plate Size (mm)	Hole Centres (mm)	Load Capacity (kg)	SWIVEL Part number	BRAKED Part number	FIXED Part number
80	30	100	105 X 80	80 X 60	100	RT3LPPU-RB	RT3LPBPU-RB	RT3LFPPU-RB
100	35	125	105 X 80	80 X 60	200	RT4LPPU-RB	RT4LPBPU-RB	RT4LFPPU-RB
125	35	155	105 X 80	80 X 60	200	RT5LPPU-RB	RT5LPBPU-RB	RT5LFPPU-RB



Tubular Fittings



Thread Guards

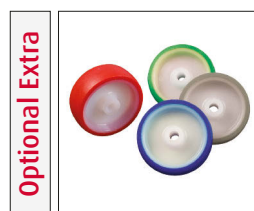

Colours (Minimum quantity required)



M12-M10 Reducer

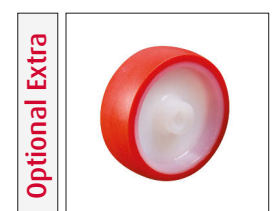

Plain Bore

Medium Duty Pressed Steel: Polyurethane tyre | Nylon centre

150mm - 200mm diameter wheel | 350kg - 400kg load capacity



- Pressed steel bracket, zinc plated
- Swivel head with double ball race
- Red polyurethane tyre, grey nylon centre wheel
- Roller bearing
- Combined swivel and wheel brake



Bolt hole fitting

Wheel Dia. (mm)	Tread Width (mm)	Overall Height (mm)	Bolt Hole Dia. (mm)	Load Capacity (kg)	SWIVEL Part number	BRAKED Part number
150	50	180	M16	350	RT6LBHPU-RB	RT6LBHBPU-RB
200	50	230	M16	400	RT8LBHPU-RB	RT8LBHBPU-RB

Plate fitting

Wheel Dia. (mm)	Tread Width (mm)	Overall Height (mm)	Plate Size (mm)	Hole Centres (mm)	Load Capacity (kg)	SWIVEL Part number	BRAKED Part number	FIXED Part number
150	50	185	135 X 110	105 X 80	350	RT6LPPU-RB	RT6LPBPU-RB	RT6LFPPU-RB
200	50	235	135 X 110	105 X 80	400	RT8LPPU-RB	RT8LPBPU-RB	RT8LFPPU-RB



Tubular Fittings



M12-M10 Reducer
M16-M12 Reducer

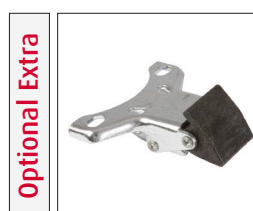

Directional Lock
Plate fitting only

Medium Duty Pressed Steel: Nylon

80mm - 200mm diameter wheel | 170kg - 400kg load capacity



- Pressed steel bracket, zinc plated
- Swivel head with double ball race
- White Nylon wheel
- Plain bore
- Combined swivel and wheel brake

Bolt hole fitting

Wheel Dia. (mm)	Tread Width (mm)	Overall Height (mm)	Bolt Hole Dia. (mm)	Load Capacity (kg)	SWIVEL Part number	BRAKED Part number
80	25	99	M12	170	RT3LBHNY-PB	RT3LBHBNY-PB
100	32	124	M12	200	RT4LBHNY-PB	RT4LBHBNY-PB
125	35	154	M12	200	RT5LBHNY-PB	RT5LBHBNY-PB
160	40	185	M16	400	RT6LBHNY-PB	RT6LBHBNY-PB
200	50	230	M16	400	RT8LBHNY-PB	RT8LBHBNY-PB

Plate fitting

Wheel Dia. (mm)	Tread Width (mm)	Overall Height (mm)	Plate Size (mm)	Hole Centres (mm)	Load Capacity (kg)	SWIVEL Part number	BRAKED Part number	FIXED Part number
80	25	100	105 X 80	80 X 60	170	RT3LPNY-PB	RT3LPBNY-PB	RT3LFPNY-PB
100	32	125	105 X 80	80 X 60	200	RT4LPNY-PB	RT4LPBNY-PB	RT4LFPNY-PB
125	35	155	105 X 80	80 X 60	200	RT5LPNY-PB	RT5LPBNY-PB	RT5LFPNY-PB
160	40	190	135 X 110	105 X 80	400	RT6LPNY-PB	RT6LPBNY-PB	RT6LFPNY-PB
200	50	235	135 X 110	105 X 80	400	RT8LPNY-PB	RT8LPBNY-PB	RT8LFPNY-PB



Tubular Fittings



Thread Guards



M12-M10 Reducer
M16-M12 Reducer



Directional Lock
Available on 160 and 200mm castors. Plate fitting only.

Medium Duty Pressed Steel: Nylon

100mm - 200mm diameter wheel | 200kg - 400kg load capacity



- Pressed steel bracket, zinc plated
- Swivel head with double ball race
- White Nylon wheel
- Roller bearing
- Combined swivel and wheel brake



Bolt hole fitting

Wheel Dia. (mm)	Tread Width (mm)	Overall Height (mm)	Bolt Hole Dia. (mm)	Load Capacity (kg)	SWIVEL Part number	BRAKED Part number
100	32	124	M12	200	RT4LBHNY-RB	RT4LBHBNY-RB
125	35	154	M12	200	RT5LBHNY-RB	RT5LBHBNY-RB
160	40	185	M16	400	RT6LBHNY-RB	RT6LBHBNY-RB
200	50	230	M16	400	RT8LBHNY-RB	RT8LBHBNY-RB

Plate fitting

Wheel Dia. (mm)	Tread Width (mm)	Overall Height (mm)	Plate Size (mm)	Hole Centres (mm)	Load Capacity (kg)	SWIVEL Part number	BRAKED Part number	FIXED Part number
100	32	125	105 X 80	80 X 60	200	RT4LPNY-RB	RT4LPBNY-RB	RT4LFPNY-RB
125	35	155	105 X 80	80 X 60	200	RT5LPNY-RB	RT5LPBNY-RB	RT5LFPNY-RB
160	40	190	135 X 110	105 X 80	400	RT6LPNY-RB	RT6LPBNY-RB	RT6LFPNY-RB
200	50	235	135 X 110	105 X 80	400	RT8LPNY-RB	RT8LPBNY-RB	RT8LFPNY-RB



Tubular Fittings



Thread Guards



M12-M10 Reducer
M16-M12 Reducer



Directional Lock
Available on 160 and 200mm castors. Plate fitting only.

Heavy Duty Pressed Steel: Elastic rubber tyre | Nylon centre

100mm - 125mm diameter wheel | 200kg load capacity



- Heavy duty pressed steel bracket, zinc plated
- Swivel head with double ball race
- Blue elastic rubber tyre, black nylon centre wheel
- Black elastic rubber tyre, black nylon centre wheel
- Roller bearing
- Combined swivel and wheel brake
- Colour matched plastic threadguards supplied with 100mm castors
- Zinc plated metal threadguards supplied with 125mm castors



Plate fitting | Blue tyre

Wheel Dia. (mm)	Tread Width (mm)	Overall Height (mm)	Plate Size (mm)	Hole Centres (mm)	Load Capacity (kg)	SWIVEL Part number	BRAKED Part number	FIXED Part number
100	35/25	132	105 X 80	80 X 60	200	RT4VVPBLU/S	RT4VVPBBLU/S	RT4VVPBLU/S
100	35/25	128	135 X 110	105 X 80	200	RT4LTPBLU	RT4LTPBBLU	RT4LTPBLU
125	35/25	155	105 X 80	80 X 60	200	RT5VVPBLU/S	RT5VVPBBLU/S	RT5VVPBLU/S
125	35/25	155	135 X 110	105 X 80	200	RT5LTPBLU	RT5LTPBBLU	RT5LTPBLU

Plate fitting | Black tyre

Wheel Dia. (mm)	Tread Width (mm)	Overall Height (mm)	Plate Size (mm)	Hole Centres (mm)	Load Capacity (kg)	SWIVEL Part number	BRAKED Part number	FIXED Part number
100	35/25	132	105 X 80	80 X 60	200	RT4VVPBLK/S	RT4VVPBBLK/S	RT4VVPBLK/S
100	35/25	128	135 x 110	105 x 80	200	RT4LTPBLK	RT4LTPBBLK	RT4LTPBLK
125	35/25	155	105 X 80	80 X 60	200	RT5VVPBLK/S	RT5VVPBBLK/S	RT5VVPBLK/S
125	35/25	155	135 x 110	105 x 80	200	RT5LTPBLK	RT5LTPBBLK	RT5LTPBLK

100mm castors have 132mm overall height to flight case industry requirements.



Directional Lock - Available on large top plate castors. (Plate size 135 x 110mm)



Grey Tyre

Heavy Duty Pressed Steel: Elastic rubber tyre | Nylon centre

160mm - 200mm diameter wheel | 350kg - 400kg load capacity



- Heavy duty pressed steel bracket, zinc plated
- Swivel head with double ball race
- Blue elastic rubber tyre, black nylon centre wheel

- Roller bearing
- Combined swivel and wheel brake
- Zinc plated metal threadguards supplied with 160mm castors



Plate fitting | Blue tyre

Wheel Dia. (mm)	Tread Width (mm)	Overall Height (mm)	Plate Size (mm)	Hole Centres (mm)	Load Capacity (kg)	SWIVEL Part number	BRAKED Part number	FIXED Part number
160	45/41	200	135 X 110	105 X 80	350	RT6VVPBLU/S	RT6VVPBBLU/S	RT6VVPBLU/S
200	45/38	245	135 X 110	105 X 80	400	RT8VVPBLU/S	RT8VVPBBLU/S	RT8VVPBLU/S

Optional Extra



Directional Lock

Heavy Duty Pressed Steel: Elastic rubber tyre | Aluminium centre

100mm - 125mm diameter wheel | 200kg - 250kg load capacity



- Heavy duty pressed steel bracket, zinc plated
- Swivel head with double ball race
- Black elastic rubber tyre, aluminium centre wheel
- Ball bearing
- Combined swivel and wheel brake



Plate fitting

Wheel Dia. (mm)	Tread Width (mm)	Overall Height (mm)	Plate Size (mm)	Hole Centres (mm)	Load Capacity (kg)	SWIVEL Part number	BRAKED Part number	FIXED Part number
100	39/29	132	105 X 80	80 X 60	200	RT4VVPBLKALU	RT4VVPBBLKALU	RT4VVPBBLKALU
100	39/29	128	135 X 110	105 X 80	200	RT4LTPBLKALU	RT4LTPBBLKALU	RT4LTPBBLKALU
125	39/29	155	105 X 80	80 X 60	250	RT5VVPBLKALU	RT5VVPBBLKALU	RT5VVPBBLKALU
125	39/29	155	135 X 110	105 X 80	250	RT5LTPBLKALU	RT5LTPBBLKALU	RT5LTPBBLKALU

Optional Extra



Directional Lock - Available on large top plate castors. (Plate size 135 x 110mm)

Heavy Duty Pressed Steel: Elastic rubber tyre | Aluminium centre

160mm - 200mm diameter wheel | 350kg - 450kg load capacity



- Heavy duty pressed steel bracket, zinc plated
- Swivel head with double ball race
- Black elastic rubber tyre, aluminium centre wheel
- Ball bearing
- Combined swivel and wheel brake



Plate fitting

Wheel Dia. (mm)	Tread Width (mm)	Overall Height (mm)	Plate Size (mm)	Hole Centres (mm)	Load Capacity (kg)	SWIVEL Part number	BRAKED Part number	FIXED Part number
160	50/38	200	135 X 110	105 X 80	350	RT6VVPBLKALU	RT6VVPBBLKALU	RT6VVFPBLKALU
200	50/33	245	135 X 110	105 X 80	450	RT8VVPBLKALU	RT8VVPBBLKALU	RT8VVFPBLKALU

Optional Extra



Directional Lock

Optional Extra



Grey Tyre

Heavy Duty Pressed Steel: Elastic rubber tyre | Cast iron centre

150mm - 200mm diameter wheel | 400kg - 600kg load capacity



- Heavy duty pressed steel bracket, zinc plated
- Swivel head with double ball race
- Black elastic rubber tyre, cast iron centre wheel
- Ball bearing
- Combined swivel and wheel brake



Plate fitting

Wheel Dia. (mm)	Tread Width (mm)	Overall Height (mm)	Plate Size (mm)	Hole Centres (mm)	Load Capacity (kg)	SWIVEL Part number	BRAKED Part number	FIXED Part number
150	50/43	195	135 X 110	105 X 80	400	RT6VVPCIBLK-BB	RT6VVPBCIBLK-BB	RT6VVFPCIBLK-BB
200	50/46	245	135 X 110	105 X 80	600	RT8VVPCIBLK-BB	RT8VVPBCIBLK-BB	RT8VVFPCIBLK-BB

Optional Extra



Directional Lock

Heavy Duty Pressed Steel: Polyurethane tyre | Nylon centre

100mm - 125mm diameter wheel | 220kg - 300kg load capacity



- Heavy duty pressed steel bracket, zinc plated
- Swivel head with double ball race
- Red polyurethane tyre, white nylon centre wheel
- Wheel bearing options:
 - Plain bore
 - Roller bearing
- Combined swivel and wheel brake



Plate fitting

Wheel Dia. (mm)	Tread Width (mm)	Bearing Type	Overall Height (mm)	Plate Size (mm)	Hole Centres (mm)	Load Capacity (kg)	SWIVEL Part number	BRAKED Part number	FIXED Part number
100	35	Plain	132	105 X 80	80 X 60	220	RT4VVPPU-PB	RT4VVPBPU-PB	RT4VVFPPU-PB
100	35	Roller	132	105 X 80	80 X 60	220	RT4VVPPU-RB	RT4VVPBPU-RB	RT4VVFPPU-RB
100	35	Plain	128	135 X 110	105 X 80	220	RT4LTPPU-PB	RT4LTPBPU-PB	RT4LTFPPU-PB
100	35	Roller	128	135 X 110	105 X 80	220	RT4LTPPU-RB	RT4LTPBPU-RB	RT4LTFPPU-RB
125	35	Plain	155	105 X 80	80 X 60	300	RT5VVPPU-PB	RT5VVPBPU-PB	RT5VVFPPU-PB
125	35	Roller	155	105 X 80	80 X 60	300	RT5VVPPU-RB	RT5VVPBPU-RB	RT5VVFPPU-RB
125	35	Plain	155	135 X 110	105 X 80	300	RT5LTPPU-PB	RT5LTPBPU-PB	RT5LTFPPU-PB
125	35	Roller	155	135 X 110	105 X 80	300	RT5LTPPU-RB	RT5LTPBPU-RB	RT5LTFPPU-RB

Optional Extra



Thread Guards

Optional Extra



Directional Lock - Available on large top plate castors. (Plate size 135 x 110mm)

Heavy Duty Pressed Steel: Polyurethane tyre | Nylon centre

150mm - 200mm diameter wheel | 350kg - 400kg load capacity



- Heavy duty pressed steel bracket, zinc plated
- Swivel head with double ball race
- Red polyurethane tyre, grey nylon centre wheel
- Roller bearing
- Combined swivel and wheel brake



Plate fitting

Wheel Dia. (mm)	Tread Width (mm)	Bearing Type	Overall Height (mm)	Plate Size (mm)	Hole Centres (mm)	Load Capacity (kg)	SWIVEL Part number	BRAKED Part number	FIXED Part number
150	50	Roller	195	135 X 110	105 X 80	350	RT6VVPPU-RB	RT6VVPBPU-RB	RT6VVFPPU-RB
200	50	Roller	245	135 X 110	105 X 80	400	RT8VVPPU-RB	RT8VVPBPU-RB	RT8VVFPPU-RB

Optional Extra



Directional Lock

Heavy Duty Pressed Steel: Polyurethane tyre | Nylon centre

160mm - 200mm diameter wheel | 600kg load capacity



- Heavy duty pressed steel bracket, zinc plated
- Swivel head with double ball race
- Brown polyurethane tyre, black reinforced glass fibre centre wheel

- Ball bearing complete with plastic threadguards
- Combined swivel and wheel brake



Plate fitting

Wheel Dia. (mm)	Tread Width (mm)	Overall Height (mm)	Plate Size (mm)	Hole Centres (mm)	Load Capacity (kg)	SWIVEL Part number	BRAKED Part number	FIXED Part number
160	46	200	135 X 110	105 X 80	600	RT6VVPPU-BB	RT6VVPBPU-BB	RT6VVFPPU-BB
200	50	245	135 X 110	105 X 80	600	RT8VVPPU-BB	RT8VVPBPU-BB	RT8VVFPPU-BB

Optional Extra



Directional Lock

Heavy Duty Pressed Steel: Polyurethane tyre | Aluminium centre

100mm - 125mm diameter wheel | 225kg - 275kg load capacity



- Heavy duty pressed steel bracket, zinc plated
- Swivel head with double ball race
- Polyurethane tyre, aluminium centre wheel
- Ball bearing
- Combined swivel and wheel brake



Plate fitting

Wheel Dia. (mm)	Tread Width (mm)	Overall Height (mm)	Plate Size (mm)	Hole Centres (mm)	Load Capacity (kg)	SWIVEL Part number	BRAKED Part number	FIXED Part number
100	30	132	105 X 80	80 X 60	225	RT4VPPUALU	RT4VVPBUALU	RT4VVFPPUALU
100	30	128	135 X 110	105 X 80	225	RT4LTPUALU	RT4LTPBUALU	RT4LTFPPUALU
125	30	155	105 X 80	80 X 60	275	RT5VPPUALU	RT5VVPBUALU	RT5VVFPPUALU
125	30	155	135 X 110	105 X 80	275	RT5LTPUALU	RT5LTPBUALU	RT5LTFPPUALU

Optional Extra



Directional Lock - Available on large top plate castors. (Plate size 135 x 110mm)

Heavy Duty Pressed Steel: Polyurethane tyre | Aluminium centre

160mm - 200mm diameter wheel | 600kg load capacity



- Heavy duty pressed steel bracket, zinc plated
- Swivel head with double ball race
- Polyurethane tyre, aluminium centre wheel
- Ball bearing
- Combined swivel and wheel brake



Plate fitting

Wheel Dia. (mm)	Tread Width (mm)	Overall Height (mm)	Plate Size (mm)	Hole Centres (mm)	Load Capacity (kg)	SWIVEL Part number	BRAKED Part number	FIXED Part number
160	50	200	135 X 110	105 X 80	600	RT6VVPPUALU	RT6VVPBUALU	RT6VVFPPUALU
200	50	245	135 X 110	105 X 80	600	RT8VVPPUALU	RT8VVPBUALU	RT8VVFPPUALU

Optional Extra



Directional Lock

Heavy Duty Pressed Steel: Polyurethane tyre | Cast iron centre

100mm - 125mm diameter wheel | 250kg - 300kg load capacity



- Heavy duty pressed steel bracket, zinc plated
- Swivel head with double ball race
- Polyurethane tyre, cast iron centre wheel
- Ball bearing
- Combined swivel and wheel brake



Plate fitting

Wheel Dia. (mm)	Tread Width (mm)	Overall Height (mm)	Plate Size (mm)	Hole Centres (mm)	Load Capacity (kg)	SWIVEL Part number	BRAKED Part number	FIXED Part number
100	30	132	105 X 80	80 X 60	250	RT4VVP CIPU-BB	RT4VVPBCIPU-BB	RT4VVFPCIPU-BB
100	30	128	135 X 110	105 X 80	250	RT4LTP CIPU-BB	RT4LTPBCIPU-BB	RT4LTFPCIPU-BB
125	30	155	105 X 80	80 X 60	300	RT5VVP CIPU-BB	RT5VVPBCIPU-BB	RT5VVFPCIPU-BB
125	30	155	135 X 110	105 X 80	300	RT5LTP CIPU-BB	RT5LTPBCIPU-BB	RT5LTFPCIPU-BB

Optional Extra



Directional Lock - Available on large top plate castors.
(Plate size 135 x 110mm)

Heavy Duty Pressed Steel: Polyurethane tyre | Cast iron centre

150mm - 200mm diameter wheel | 600kg load capacity



- Heavy duty pressed steel bracket, zinc plated
- Swivel head with double ball race
- Polyurethane tyre, cast iron centre wheel
- Ball bearing
- Combined swivel and wheel brake



Plate fitting

Wheel Dia. (mm)	Tread Width (mm)	Overall Height (mm)	Plate Size (mm)	Hole Centres (mm)	Load Capacity (kg)	SWIVEL Part number	BRAKED Part number	FIXED Part number
150	50	195	135 X 110	105 X 80	600	RT6VVPCIPU-BB	RT6VVPBCIPU-BB	RT6VVFPCIPU-BB
200	50	245	135 X 110	105 X 80	600	RT8VVPCIPU-BB	RT8VVPBCIPU-BB	RT8VVFPCIPU-BB

Optional Extra



Directional Lock

Heavy Duty Pressed Steel: Nylon

100mm - 125mm diameter wheel | 250kg - 300kg load capacity



- Heavy duty pressed steel bracket, zinc plated
- Swivel head with double ball race
- White nylon wheel
- Wheel bearing options:
 - Plain bore
 - Roller bearing
- Combined swivel and wheel brake



Plate fitting | Plain bore

Wheel Dia. (mm)	Tread Width (mm)	Overall Height (mm)	Plate Size (mm)	Hole Centres (mm)	Load Capacity (kg)	SWIVEL Part number	BRAKED Part number	FIXED Part number
100	32	132	105 X 80	80 X 60	250	RT4VVPNY	RT4VVPBNY	RT4VVFPPNY
100	32	128	135 X 110	105 X 80	250	RT4LTPNY	RT4LTPBNY	RT4LTFPPNY
125	35	155	105 X 80	80 X 60	300	RT5VVPNY	RT5VVPBNY	RT5VVFPPNY
125	35	155	135 X 110	105 X 80	300	RT5LTPNY	RT5LTPBNY	RT5LTFPPNY

Plate fitting | Roller bearing

Wheel Dia. (mm)	Tread Width (mm)	Overall Height (mm)	Plate Size (mm)	Hole Centres (mm)	Load Capacity (kg)	SWIVEL Part number	BRAKED Part number	FIXED Part number
100	32	132	105 X 80	80 X 60	250	RT4VVPNY-RB	RT4VVPBNY-RB	RT4VVFPPNY-RB
100	32	128	135 X 110	105 X 80	250	RT4LTPNY-RB	RT4LTPBNY-RB	RT4LTFPPNY-RB
125	35	155	105 X 80	80 X 60	300	RT5VVPNY-RB	RT5VVPBNY-RB	RT5VVFPPNY-RB
125	35	155	135 X 110	105 X 80	300	RT5LTPNY-RB	RT5LTPBNY-RB	RT5LTFPPNY-RB

Optional Extra



Directional Lock - Available on large top plate castors. (Plate size 135 x 110mm)

Optional Extra



Thread Guards

Heavy Duty Pressed Steel: Nylon

160mm - 200mm diameter wheel | 400kg - 600kg load capacity



- Heavy duty pressed steel bracket, zinc plated
- Swivel head with double ball race
- White nylon wheel
- Wheel bearing options:
 - Plain bore
 - Roller bearing
- Combined swivel and wheel brake



Plate fitting | Plain bore

Wheel Dia. (mm)	Tread Width (mm)	Overall Height (mm)	Plate Size (mm)	Hole Centres (mm)	Load Capacity (kg)	SWIVEL Part number	BRAKED Part number	FIXED Part number
160	40	200	135 X 110	105 X 80	400	RT6VVPNY	RT6VVPBNY	RT6VVFPNY
200	50	245	135 X 110	105 X 80	600	RT8VVPNY	RT8VVPBNY	RT8VVFPNY

Plate fitting | Roller bearing

Wheel Dia. (mm)	Tread Width (mm)	Overall Height (mm)	Plate Size (mm)	Hole Centres (mm)	Load Capacity (kg)	SWIVEL Part number	BRAKED Part number	FIXED Part number
160	40	200	135 X 110	105 X 80	400	RT6VVPNY-RB	RT6VVPBNY-RB	RT6VVFPNY-RB
200	50	245	135 X 110	105 X 80	600	RT8VVPNY-RB	RT8VVPBNY-RB	RT8VVFPNY-RB

Optional Extra



Directional Lock

Heavy Duty Pressed Steel: Nylon

160mm - 200mm diameter wheel | 600kg load capacity



- Heavy duty pressed steel bracket, zinc plated
- Swivel head with double ball race
- Grey nylon tyre, reinforced glass fibre centre wheel
- Ball bearing complete with plastic threadguards
- Combined swivel and wheel brake



Plate fitting | Plain bore

Wheel Dia. (mm)	Tread Width (mm)	Overall Height (mm)	Plate Size (mm)	Hole Centres (mm)	Load Capacity (kg)	SWIVEL Part number	BRAKED Part number	FIXED Part number
160	46	200	135 X 110	105 X 80	600	RT6VVPNY-BB	RT6VVPBNY-BB	RT6VVFPNY-BB
200	50	245	135 X 110	105 X 80	600	RT8VVPNY-BB	RT8VVPBNY-BB	RT8VVFPNY-BB

Optional Extra



Directional Lock

Heavy Duty Pressed Steel Towable: Elastic Rubber Tyre | Aluminium centre

160mm - 250mm diameter wheel | 350kg - 650kg load capacity



- Reinforced heavy duty pressed steel bracket, zinc plated
- Swivel head with sealed, hardened double ball race and grease nipple
- Black elastic rubber tyred aluminium centre wheel
- Towable (Maximum towing speed 4 km/h)
- Ball bearing
- Combined swivel and wheel brake



Plate fitting

Wheel Dia. (mm)	Tread Width (mm)	Overall Height (mm)	Plate Size (mm)	Hole Centres (mm)	Load Capacity (kg)	SWIVEL Part number	BRAKED Part number	FIXED Part number
160	50/38	215	135 X 110	105 X 75/80	350	RT6LVPBLKALU	RT6LVPBBLKALU	RT6LVFPBLKALU
200	50/38	245	135 X 110	105 X 75/80	450	RT8LVPBLKALU	RT8LVPBBLKALU	RT8LVFPBLKALU
250	50/38	297	135 X 110	105 X 75/80	650	RT10LVPBLKALU	RT10LVPBBLKALU	RT10LVFPBLKALU

Optional Extra



Directional Lock

Heavy Duty Pressed Steel Towable: Elastic Rubber Tyre | Aluminium centre

160mm - 200mm diameter wheel | 350kg - 450kg load capacity



- Reinforced heavy duty pressed steel bracket, zinc plated
- Swivel head with sealed, hardened double ball race and grease nipple
- Grey elastic rubber tyre, aluminium centre wheel
- Towable (Maximum towing speed 4 km/h)
- Ball bearing
- Combined swivel and wheel brake



Plate fitting

Wheel Dia. (mm)	Tread Width (mm)	Overall Height (mm)	Plate Size (mm)	Hole Centres (mm)	Load Capacity (kg)	SWIVEL Part number	BRAKED Part number	FIXED Part number
160	50/38	215	135 X 110	105 X 75/80	350	RT6LVPGRYALU	RT6LVPBGRYALU	RT6LVFPGRYALU
200	50/38	245	135 X 110	105 X 75/80	450	RT8LVPGRYALU	RT8LVPBGRYALU	RT8LVFPGRYALU

Optional Extra



Directional Lock

Heavy Duty Pressed Steel Towable: Rubber tyre | Cast iron centre

150mm - 250mm diameter wheel | 400kg - 700kg load capacity



- Reinforced heavy duty pressed steel bracket, zinc plated
- Swivel head with sealed, hardened double ball race and grease nipple
- Black elastic rubber tyre, cast iron centre wheel
- Towable (Maximum towing speed 4 km/h)
- Ball bearing
- Combined swivel and wheel brake



Plate fitting

Wheel Dia. (mm)	Tread Width (mm)	Overall Height (mm)	Plate Size (mm)	Hole Centres (mm)	Load Capacity (kg)	SWIVEL Part number	BRAKED Part number	FIXED Part number
150	50/43	210	135 X 110	105 X 75/80	400	RT6LVPCIBLK-BB	RT6LVPBCIBLK-BB	RT6LVFPCIBLK-BB
200	50/46	245	135 X 110	105 X 75/80	600	RT8LVPCIBLK-BB	RT8LVPBCIBLK-BB	RT8LVFPCIBLK-BB
250	50/46	297	135 X 110	105 X 75/80	700	RT10LVPCIBLK-BB	RT10LVPBCIBLK-BB	RT10LVFPCIBLK-BB

Optional Extra



Directional Lock

Heavy Duty Pressed Steel Towable: Polyurethane Tyre | Nylon centre

160mm - 200mm diameter wheel | 650kg - 800kg load capacity



- Reinforced heavy duty pressed steel bracket, zinc plated
- Swivel head with sealed, hardened double ball race and grease nipple
- Brown polyurethane tyre, black reinforced glass fibre centre wheel
- Towable (Maximum towing speed 4 km/h)
- Ball bearing complete with plastic threadguards
- Combined swivel and wheel brake



Plate fitting

Wheel Dia. (mm)	Tread Width (mm)	Overall Height (mm)	Plate Size (mm)	Hole Centres (mm)	Load Capacity (kg)	SWIVEL Part number	BRAKED Part number	FIXED Part number
160	46	215	135 X 110	105 X 75/80	650	RT6LVPPU-BB	RT6LVPBPU-BB	RT6LVFPPU-BB
200	50	245	135 X 110	105 X 75/80	800	RT8LVPPU-BB	RT8LVPBPU-BB	RT8LVFPPU-BB

Optional Extra



Directional Lock

Heavy Duty Pressed Steel Towable: Polyurethane Tyre | Aluminium centre

160mm - 200mm diameter wheel | 600kg - 800kg load capacity



- Reinforced heavy duty pressed steel bracket, zinc plated
- Swivel head with sealed, hardened double ball race and grease nipple
- Polyurethane tyre, aluminium centre wheel
- Towable (Maximum towing speed 4 km/h)
- Ball bearing
- Combined swivel and wheel brake



Plate fitting

Wheel Dia. (mm)	Tread Width (mm)	Overall Height (mm)	Plate Size (mm)	Hole Centres (mm)	Load Capacity (kg)	SWIVEL Part number	BRAKED Part number	FIXED Part number
160	50	215	135 X 110	105 X 75/80	600	RT6LVPPUALU	RT6LVPBPUALU	RT6LVFPPUALU
200	50	245	135 X 110	105 X 75/80	800	RT8LVPPUALU	RT8LVPBPUALU	RT8LVFPPUALU

Optional Extra



Directional Lock

Heavy Duty Pressed Steel Towable: Polyurethane tyre | Cast iron centre

150mm - 250mm diameter wheel | 800kg - 1000kg load capacity



- Reinforced heavy duty pressed steel bracket, zinc plated
- Swivel head with sealed, hardened double ball race and grease nipple
- Brown polyurethane tyre, cast iron centre wheel
- Towable (Maximum towing speed 4 km/h)
- Ball bearing
- Combined swivel and wheel brake



Plate fitting

Wheel Dia. (mm)	Tread Width (mm)	Overall Height (mm)	Plate Size (mm)	Hole Centres (mm)	Load Capacity (kg)	SWIVEL Part number	BRAKED Part number	FIXED Part number
150	50	210	135 X 110	105 X 75/80	800	RT6LVPCIPU-BB	RT6LVPBCIPU-BB	RT6LVFPCIPU-BB
200	50	245	135 X 110	105 X 75/80	1000	RT8LVPCIPU-BB	RT8LVPBCIPU-BB	RT8LVFPCIPU-BB
250	50	297	135 X 110	105 X 75/80	1000	RT10LVPCIPU-BB	RT10LVPBCIPU-BB	RT10LVFPCIPU-BB

Optional Extra



Directional Lock

Heavy Duty Pressed Steel Towable: Polyurethane Crown Turned Tyre | Cast iron

150mm - 200mm diameter wheel | 650kg - 800kg load capacity



- Reinforced heavy duty pressed steel bracket, zinc plated
- Swivel head with sealed, hardened double ball race and grease nipple
- Brown polyurethane crown turned tyre, cast iron centre wheel
- Towable (Maximum towing speed 4 km/h)
- Ball bearing
- Combined swivel and wheel brake



Plate fitting

Wheel Dia. (mm)	Tread Width (mm)	Overall Height (mm)	Plate Size (mm)	Hole Centres (mm)	Load Capacity (kg)	SWIVEL Part number	BRAKED Part number	FIXED Part number
150	50	210	135 X 110	105 X 75/80	650	RT6LVPCTCI-BB	RT6LVPBCTCI-BB	RT6LVFPCTCI-BB
200	50	245	135 X 110	105 X 75/80	800	RT8LVPCTCI-BB	RT8LVPBCTCI-BB	RT8LVFPCTCI-BB



Optional Extra

Directional Lock

Heavy Duty Pressed Steel Towable: Nylon

160mm - 200mm diameter wheel | 900kg - 1000kg load capacity



- Reinforced heavy duty pressed steel bracket, zinc plated
- Swivel head with sealed, hardened double ball race and grease nipple
- Grey nylon tyre, reinforced glass fibre centre wheel
- Towable (Maximum towing speed 4 km/h)
- Ball bearing complete with plastic threadguards
- Combined swivel and wheel brake



Plate fitting

Wheel Dia. (mm)	Tread Width (mm)	Overall Height (mm)	Plate Size (mm)	Hole Centres (mm)	Load Capacity (kg)	SWIVEL Part number	BRAKED Part number	FIXED Part number
160	46	215	135 X 110	105 X 75/80	900	RT6LVPNY-BB	RT6LVPBNI-BB	RT6LVFPNY-BB
200	50	245	135 X 110	105 X 75/80	1000	RT8LVPNY-BB	RT8LVPBNI-BB	RT8LVFPNY-BB

Optional Extra



Directional Lock

Heavy Duty Fabricated Steel: Nylon

100mm - 200mm diameter wheel | 250kg - 600kg load capacity



- Heavy duty fabricated steel bracket, zinc plated
- Swivel head with hardened double ball race and grease nipple
- White nylon wheel

- Wheel bearing options:
 - Plain bore
 - Ball bearing
- Wheel brake



Plate fitting | Nylon wheel

Wheel Dia. (mm)	Tread Width (mm)	Bearing Type	Overall Height (mm)	Plate Size (mm)	Hole Centres (mm)	Load Capacity (kg)	SWIVEL Part number	BRAKED Part number	FIXED Part number
100	32	Plain	142	135 X 110	105 X 80	250	RT4SW-FAB-NY	RT4SWB-FAB-NY	RT4FX-FAB-NY
125	35	Plain	165	135 X 110	105 X 80	300	RT5SW-FAB-NY	RT5SWB-FAB-NY	RT5FX-FAB-NY
125	45	Ball	165	135 X 110	105 X 80	500	RT5SW-FAB-NY-BB	RT5SWB-FAB-NY-BB	RT5FX-FAB-NY-BB
150	45	Ball	195	135 X 110	105 X 80	600	RT6SW-FAB-NY-BB	RT6SWB-FAB-NY-BB	RT6FX-FAB-NY-BB
160	40	Plain	195	135 X 110	105 X 80	400	RT6SW-FAB-NY	N/A	RT6FX-FAB-NY
200	50	Plain	241	135 X 110	105 X 80	600	RT8SW-FAB-NY	RT8SWB-FAB-NY	RT8FX-FAB-NY
200	50	Ball	241	135 X 110	105 X 80	600	RT8SW-FAB-NY-BB	RT8SWB-FAB-NY-BB	RT8FX-FAB-NY-BB

Extra Heavy Duty Fabricated Steel Towable: Elastic rubber tyre | Aluminium centre

160mm - 200mm diameter wheel | 350kg - 450kg load capacity



- Extra heavy duty fabricated steel bracket, zinc plated
- Swivel head with sealed, hardened ball race and additional thrust bearing, bolted kingpin
- Black elastic rubber tyre, aluminium centre wheel
- Towable (maximum towing speed 4 km/h)
- Ball bearing
- Combined swivel and wheel brake



Plate fitting

Wheel Dia. (mm)	Tread Width (mm)	Overall Height (mm)	Plate Size (mm)	Hole Centres (mm)	Load Capacity (kg)	SWIVEL Part number	BRAKED Part number	FIXED Part number
160	50/38	205	150 X 110	$\frac{121 \times 59}{105 \times 80}$	350	RT6XPBLKALU	RT6XPBBLKALU	RT6XFPBLKALU
200	50/38	250	150 X 110	$\frac{121 \times 59}{105 \times 80}$	450	RT8XPBLKALU	RT8XPBBLKALU	RT8XFPBLKALU

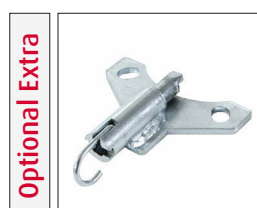

4-Way Directional Lock

Extra Heavy Duty Fabricated Steel Towable: Elastic rubber tyre | Aluminium centre

160mm - 200mm diameter wheel | 350kg - 450kg load capacity



- Extra heavy duty fabricated steel bracket, zinc plated
- Swivel head with sealed, hardened ball race and additional thrust bearing, bolted kingpin
- Grey elastic rubber tyre, aluminium centre wheel

- Towable (maximum towing speed 4 km/h)
- Ball bearing
- Combined swivel and wheel brake



Plate fitting

Wheel Dia. (mm)	Tread Width (mm)	Overall Height (mm)	Plate Size (mm)	Hole Centres (mm)	Load Capacity (kg)	SWIVEL Part number	BRAKED Part number	FIXED Part number
160	50/38	205	150 X 110	121 X 59 105 X 80	350	RT6XPGRYALU	RT6XPBGRYALU	RT6XFPGRYALU
200	50/38	250	150 X 110	121 X 59 105 X 80	450	RT8XPGRYALU	RT8XPBGRYALU	RT8XFPGRYALU

Optional Extra



4-Way Directional Lock

Extra Heavy Duty Fabricated Steel Towable: Elastic rubber tyre | Cast iron centre

150mm - 200mm diameter wheel | 400kg - 600kg load capacity



- Extra heavy duty fabricated steel bracket, zinc plated
- Swivel head with sealed, hardened ball race and additional thrust bearing, bolted kingpin
- Black elastic rubber tyre, cast iron centre wheel
- Towable (maximum towing speed 4 km/h)
- Ball bearing
- Combined swivel and wheel brake



Plate fitting

Wheel Dia. (mm)	Tread Width (mm)	Overall Height (mm)	Plate Size (mm)	Hole Centres (mm)	Load Capacity (kg)	SWIVEL Part number	BRAKED Part number	FIXED Part number
150	50/43	200	150 X 110	121 X 59 105 X 80	400	RT6XPCIBLK-BB	RT6XPBCIBLK-BB	RT6XFPCIBLK-BB
200	50/46	250	150 X 110	121 X 59 105 X 80	600	RT8XPCIBLK-BB	RT8XPBCIBLK-BB	RT8XFPCIBLK-BB

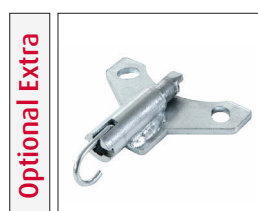

4-Way Directional Lock

Extra Heavy Duty Fabricated Steel Towable: Polyurethane tyre | Nylon centre

160mm - 200mm diameter wheel | 650kg - 800kg load capacity



- Extra heavy duty fabricated steel bracket, zinc plated
- Swivel head with sealed, hardened ball race and additional thrust bearing, bolted kingpin
- Brown polyurethane tyre, reinforced glass fibre centre wheel
- Towable (maximum towing speed 4 km/h)
- Ball bearing complete with plastic threadguards
- Combined swivel and wheel brake



Plate fitting

Wheel Dia. (mm)	Tread Width (mm)	Overall Height (mm)	Plate Size (mm)	Hole Centres (mm)	Load Capacity (kg)	SWIVEL Part number	BRAKED Part number	FIXED Part number
160	46	205	150 X 110	121 X 59 105 X 80	650	RT6XPPU-BB	RT6XPBPU-BB	RT6XFPPU-BB
200	50	250	150 X 110	121 X 59 105 X 80	800	RT8XPPU-BB	RT8XPBPU-BB	RT8XFPPU-BB



4-Way Directional Lock

Optional Extra

Extra Heavy Duty Fabricated Steel Towable: Polyurethane tyre | Cast iron centre

150mm - 200mm diameter wheel | 800kg - 1000kg load capacity



- Extra heavy duty fabricated steel bracket, zinc plated
- Swivel head with sealed, hardened ball race and additional thrust bearing, bolted kingpin
- Brown polyurethane tyre, cast iron centre wheel
- Towable (maximum towing speed 4 km/h)
- Ball bearing
- Combined swivel and wheel brake



Plate fitting

Wheel Dia. (mm)	Tread Width (mm)	Overall Height (mm)	Plate Size (mm)	Hole Centres (mm)	Load Capacity (kg)	SWIVEL Part number	BRAKED Part number	FIXED Part number
150	50	200	150 X 110	121 X 59 105 X 80	800	RT6XPCIPU-BB	RT6XPBCIPU-BB	RT6XFPCIPU-BB
200	50	250	150 X 110	121 X 59 105 X 80	1000	RT8XPCIPU-BB	RT8XPBCIPU-BB	RT8XFPCIPU-BB

Optional Extra



4-Way Directional Lock

Extra Heavy Duty Fabricated Steel Towable: Polyurethane crown turned tyre | Cast iron

150mm - 200mm diameter wheel | 650kg - 800kg load capacity



- Extra heavy duty fabricated steel bracket, zinc plated
- Swivel head with sealed, hardened ball race and additional thrust bearing, bolted kingpin
- Brown polyurethane crown turned tyre, cast iron centre wheel
- Towable (maximum towing speed 4 km/h)
- Ball bearing
- Combined swivel and wheel brake



Plate fitting

Wheel Dia. (mm)	Tread Width (mm)	Overall Height (mm)	Plate Size (mm)	Hole Centres (mm)	Load Capacity (kg)	SWIVEL Part number	BRAKED Part number	FIXED Part number
150	50	200	150 X 110	121 X 59 105 X 80	650	RT6XPCTCI-BB	RT6XPBCTCI-BB	RT6XFPCTCI-BB
200	50	250	150 X 110	121 X 59 105 X 80	800	RT8XPCTCI-BB	RT8XPBCTCI-BB	RT8XFPCTCI-BB

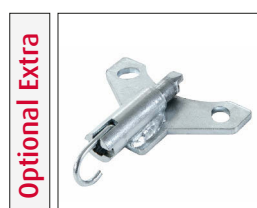

4-Way Directional Lock

Extra Heavy Duty Fabricated Steel Towable: Nylon

160mm - 200mm diameter wheel | 900kg - 1200kg load capacity



- Extra heavy duty fabricated steel bracket, zinc plated
- Swivel head with sealed, hardened ball race and additional thrust bearing, bolted kingpin
- Grey nylon tyre, reinforced glass fibre centre wheel
- Towable (maximum towing speed 4 km/h)
- Ball bearing complete with plastic threadguards
- Combined swivel and wheel brake



Plate fitting

Wheel Dia. (mm)	Tread Width (mm)	Overall Height (mm)	Plate Size (mm)	Hole Centres (mm)	Load Capacity (kg)	SWIVEL Part number	BRAKED Part number	FIXED Part number
160	46	205	150 X 110	$\frac{121 \times 59}{105 \times 80}$	900	RT6XPNY-BB	RT6XPBNY-BB	RT6XFPNY-BB
200	50	250	150 X 110	$\frac{121 \times 59}{105 \times 80}$	1200	RT8XPNY-BB	RT8XPBNY-BB	RT8XFPNY-BB



4-Way Directional Lock

Extra Heavy Duty Fabricated Steel Towable: Cast iron

150mm - 200mm diameter wheel | 900kg - 1100kg load capacity



- Extra heavy duty fabricated steel bracket, zinc plated
- Swivel head with sealed, hardened ball race and additional thrust bearing, bolted kingpin
- Cast iron wheel
- Towable (maximum towing speed 4 km/h)
- Ball bearing
- Combined swivel and wheel brake



Plate fitting

Wheel Dia. (mm)	Tread Width (mm)	Overall Height (mm)	Plate Size (mm)	Hole Centres (mm)	Load Capacity (kg)	SWIVEL Part number	BRAKED Part number	FIXED Part number
150	50	200	150 X 110	$\frac{121 \times 59}{105 \times 80}$	900	RT6XPCI-BB	RT6XPBCI-BB	RT6XFPCI-BB
200	50	250	150 X 110	$\frac{121 \times 59}{105 \times 80}$	1100	RT8XPCI-BB	RT8XPBCI-BB	RT8XFPCI-BB

Optional Extra



4-Way Directional Lock

Twin Heavy Duty Fabricated Steel Towable: Nylon & Polyurethane tyred

150mm - 200mm diameter wheel | 1000kg - 1500kg load capacity



- Heavy duty fabricated steel bracket (Black enamel finish)
- Swivel head with hardened ball race
- White nylon or red polyurethane tyre, grey nylon centre wheel
- Ball bearing
- Towable (Maximum towing speed 4 km/h)



Plate fitting | Nylon wheel

Wheel Dia. (mm)	Tread Width (mm)	Overall Height (mm)	Plate Size (mm)	Hole Centres (mm)	Load Capacity (kg)	SWIVEL Part number	FIXED Part number
150	50/50	202	150 x 110	$\frac{121 \times 59}{105 \times 80}$	1500	RT6SW-HDFAB-NY-TW	RT6FX-HDFAB-NY-TW
200	50/50	252	150 x 110	$\frac{121 \times 59}{105 \times 80}$	1500	RT8SW-HDFAB-NY-TW	RT8FX-HDFAB-NY-TW

Plate fitting | Polyurethane tyre | Nylon centre

Wheel Dia. (mm)	Tread Width (mm)	Overall Height (mm)	Plate Size (mm)	Hole Centres (mm)	Load Capacity (kg)	SWIVEL Part number	FIXED Part number
150	50/50	202	150 x 110	$\frac{121 \times 59}{105 \times 80}$	1000	RT6SW-HDFAB-PU-TW	RT6FX-HDFAB-PU-TW
200	50/50	252	150 x 110	$\frac{121 \times 59}{105 \times 80}$	1000	RT8SW-HDFAB-PU-TW	RT8FX-HDFAB-PU-TW

Twin Heavy Duty Fabricated Steel Towable: Rubber tyre | Cast iron centre & cast iron

150mm - 200mm diameter wheel | 800kg - 1500kg load capacity



- Heavy duty fabricated steel bracket (Black enamel finish)
- Swivel head with hardened ball race
- Black elastic rubber tyre, cast iron centre wheel or cast iron wheel
- Ball bearing
- Towable (Maximum towing speed 4 km/h)



Plate fitting | Elastic rubber tyre | Cast iron centre wheel

Wheel Dia. (mm)	Tread Width (mm)	Overall Height (mm)	Plate Size (mm)	Hole Centres (mm)	Load Capacity (kg)	SWIVEL Part number	FIXED Part number
150	50/50	202	150 x 110	$\frac{121 \times 59}{105 \times 80}$	800	RT6SW-HDFAB-CIRT-TW	RT6FX-HDFAB-CIRT-TW
200	50/50	252	150 x 110	$\frac{121 \times 59}{105 \times 80}$	1200	RT8SW-HDFAB-CIRT-TW	RT8FX-HDFAB-CIRT-TW

Plate fitting | Cast iron wheel

Wheel Dia. (mm)	Tread Width (mm)	Overall Height (mm)	Plate Size (mm)	Hole Centres (mm)	Load Capacity (kg)	SWIVEL Part number	FIXED Part number
150	50/50	202	150 x 110	$\frac{121 \times 59}{105 \times 80}$	1500	RT6SW-HDFAB-CI-TW	RT6FX-HDFAB-CI-TW
200	50/50	252	150 x 110	$\frac{121 \times 59}{105 \times 80}$	1500	RT8SW-HDFAB-CI-TW	RT8FX-HDFAB-CI-TW

Twin Heavy Duty Fabricated Steel Towable: Polyurethane tyre | Cast iron centre

150mm - 200mm diameter wheel | 1500kg load capacity



- Heavy duty fabricated steel bracket (Black enamel finish)
- Swivel head with hardened ball race
- Brown polyurethane tyre, cast iron centre wheel
- Ball bearing
- Towable (Maximum towing speed 4 km/h)



Plate fitting | Polyurethane tyre | Cast iron centre wheel

Wheel Dia. (mm)	Tread Width (mm)	Overall Height (mm)	Plate Size (mm)	Hole Centres (mm)	Load Capacity (kg)	SWIVEL Part number	FIXED Part number
150	50/50	202	150 x 110	$\frac{121 \times 59}{105 \times 84}$	1500	RT6SW-HDFAB-CIPU-TW	RT6FX-HDFAB-CIPU-TW
200	50/50	252	150 x 110	$\frac{121 \times 59}{105 \times 84}$	1500	RT8SW-HDFAB-CIPU-TW	RT8FX-HDFAB-CIPU-TW

Twin Extra Heavy Duty Fabricated Steel Towable: Nylon

150mm - 250mm diameter wheel | 2000kg load capacity



- Heavy duty fabricated steel bracket (Black enamel finish)
- Swivel head with hardened ball race
- White nylon wheel
- Ball bearing
- Towable (Maximum towing speed 4 km/h)



Plate fitting | Nylon wheel

Wheel Dia. (mm)	Tread Width (mm)	Overall Height (mm)	Plate Size (mm)	Hole Centres (mm)	Load Capacity (kg)	SWIVEL Part number	FIXED Part number
150	50/50	214	175 x 140	140 x 105	2000	RT6SW-XHDFAB-NY-TW	RT6FX-XHDFAB-NY-TW
200	50/50	264	175 x 140	140 x 105	2000	RT8SW-XHDFAB-NY-TW	RT8FX-XHDFAB-NY-TW
250	50/50	315	175 x 140	140 x 105	2000	RT10SW-XHDFAB-NY-TW	RT10FX-XHDFAB-NY-TW

Twin Extra Heavy Duty Fabricated Towable: Polyurethane tyre | Cast iron & Cast iron centre

150mm - 250mm diameter wheel | 1600kg - 2000kg load capacity



- Heavy duty fabricated steel bracket (Black enamel finish)
- Swivel head with precision bearing
- Brown polyurethane tyre, cast iron centre wheel or cast iron wheel
- Ball bearing
- Towable (Maximum towing speed 4 km/h)



Plate fitting | Polyurethane tyre | Cast iron centre wheel

Wheel Dia. (mm)	Tread Width (mm)	Overall Height (mm)	Plate Size (mm)	Hole Centres (mm)	Load Capacity (kg)	SWIVEL Part number	FIXED Part number
150	50/50	214	175 x 140	140 x 105	1600	RT6SW-XHDFAB-CIPU-TW	RT6FX-XHDFAB-CIPU-TW
200	50/50	264	175 x 140	140 x 105	2000	RT8SW-XHDFAB-CIPU-TW	RT8FX-XHDFAB-CIPU-TW
250	50/50	315	175 x 140	140 x 105	2000	RT10SW-XHDFAB-CIPU-TW	RT10FX-XHDFAB-CIPU-TW

Plate fitting | Solid cast iron wheel

Wheel Dia. (mm)	Tread Width (mm)	Overall Height (mm)	Plate Size (mm)	Hole Centres (mm)	Load Capacity (kg)	SWIVEL Part number	FIXED Part number
150	50/50	214	175 x 140	140 x 105	1800	RT6SW-XHDFAB-CI-TW	RT6FX-XHDFAB-CI-TW
200	50/50	264	175 x 140	140 x 105	2000	RT8SW-XHDFAB-CI-TW	RT8FX-XHDFAB-CI-TW
250	50/50	315	175 x 140	140 x 105	2000	RT10SW-XHDFAB-CI-TW	RT10FX-XHDFAB-CI-TW

Truck Locks

Truck locks are designed to be bolted to the underside of a truck or trolley to provide a ready means of instantly securing a truck or trolley in a fixed position (but do not raise it).

The operating force is moderate (and does not vary with the load), as the 'over-centre' linkage presses the rubber pad into firm contact with the floor without lifting the castors off the ground.

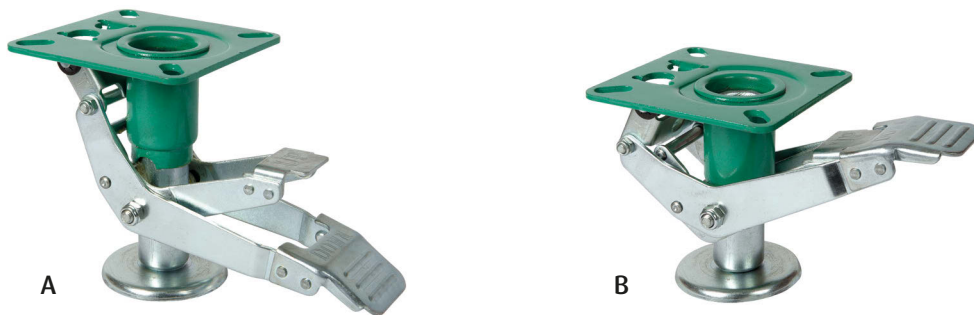

Pressed Steel, Zinc plated

Part number	Mounting Height [A] (mm)	Retracted Height [B] (mm)	Plate Size (mm)	Hole Centres (mm)	Fixing Bolt (mm)
RTTL125	148	125	120 X 120	85 x 85 and 100 x 100	11
RTTL153	176	153	120 X 120	85 x 85 and 100 x 100	11
RTTL168	204	168	120 X 120	85 x 85 and 100 x 100	11
RTTL212	248	212	120 X 120	85 x 85 and 100 x 100	11



Cast Iron, Black paint finish

Part number	Mounting Height [A] (mm)	Retracted Height [B] (mm)	Plate Size (mm)	Hole Centres (mm)	Fixing Bolt (mm)
RTTL3	200	163.5	152 x 114	127 x 635	12



SPECIALIST CASTORS



Medium Duty Pressed Stainless Steel

304 Grade Stainless Steel

80mm - 200mm diameter wheel | 100kg - 400kg load capacity



- 304 Grade Stainless Steel
- Pressed stainless steel bracket and axle material
- Swivel head with double ball race
- Nylon wheel
- Plain bore
- Combined swivel and wheel brake

Bolt hole fitting

Wheel Dia. (mm)	Tread Width (mm)	Overall Height (mm)	Bolt Hole Dia. (mm)	Load Capacity (kg)	SWIVEL Part number	BRAKED Part number
80	30	108	M12	100	RT3-DSSBHNY	RT3-DSSBHBNY
100	35	128	M12	150	RT4-DSSBHNY	RT4-DSSBHBNY
125	40	155	M12	200	RT5-DSSBHNY	RT5-DSSBHBNY

Plate fitting

Wheel Dia. (mm)	Tread Width (mm)	Overall Height (mm)	Plate Size (mm)	Hole Centres (mm)	Load Capacity (kg)	SWIVEL Part number	BRAKED Part number	FIXED Part number
80	30	108	105 X 85	80 X 60	100	RT3-DSSPNY	RT3-DSSPBNY	RT3-DSSFPNY
100	35	128	105 X 85	80 X 60	150	RT4-DSSPNY	RT4-DSSPBNY	RT4-DSSFPNY
125	40	155	105 X 85	80 X 60	200	RT5-DSSPNY	RT5-DSSPBNY	RT5-DSSFPNY
160	40	200	140 X 110	105 X 80/75	350	RT6-DSSPNY	RT6-DSSPBNY	RT6-DSSFPNY
200	50	240	140 X 110	105 X 80/75	400	RT8-DSSPNY	RT8-DSSPBNY	RT8-DSSFPNY



Tubular Fittings



Wheel Options

Heavy Duty Pressed Stainless Steel

304 Grade Stainless Steel

80mm - 200mm diameter wheel | 170kg - 450kg load capacity



- 304 Grade Stainless Steel
- Stainless steel pressed steel bracket and axle material
- Swivel head with double ball race
- Nylon wheel
- Plain bore
- Combined swivel and wheel brake

Bolt hole fitting

Wheel Dia. (mm)	Tread Width (mm)	Overall Height (mm)	Plate Size (mm)	Load Capacity (kg)	SWIVEL Part number	BRAKED Part number
80	25	106	M12	170	RT3SSLBHNY	RT3SSLBHBNY
100	32	127	M12	250	RT4SSLBHNY	RT4SSLBHBNY
125	35	156	M12	250	RT5SSLBHNY	RT5SSLBHBNY
160	40	195	M12	450	RT6SSLBHNY	RT6SSLBHBNY
200	50	237	M12	450	RT8SSLBHNY	RT8SSLBHBNY

Plate fitting

Wheel Dia. (mm)	Tread Width (mm)	Overall Height (mm)	Plate Size (mm)	Hole Centres (mm)	Load Capacity (kg)	SWIVEL Part number	BRAKED Part number	FIXED Part number
80	25	106	105 X 80	80 X 60	170	RT3SSLPNY	RT3SSLPBNY	RT3SSLFPNY
100	32	127	105 X 80	80 X 60	250	RT4SSLPNY	RT4SSLPBNY	RT4SSLFPNY
125	35	156	105 X 80	80 X 60	250	RT5SSLPNY	RT5SSLPBNY	RT5SSLFPNY
160	40	195	135 X 105	105 X 80	450	RT6SSLPNY	RT6SSLPBNY	RT6SSLFPNY
200	50	237	135 X 105	105 X 80	450	RT8SSLPNY	RT8SSLPBNY	RT8SSLFPNY

Fabricated stainless steel EXTRA HEAVY DUTY castors also available, providing load capacities up to 1300Kg.



Tubular Fittings



Wheel Options

Light Duty Pressed Steel: Anti Static

50mm - 125mm diameter wheel | 40kg - 100kg load capacity



- Pressed steel bracket, zinc plated
- Swivel head with double ball race
- Anti-static, non marking grey TPR tyre, complete with threadguards
- Plain bore (50-100 mm), Ball bearing (125 mm)
- Wheel brake (50 mm), Swivel and wheel brake (75-125 mm)

Bolt hole fitting

Wheel Dia. (mm)	Tread Width (mm)	Overall Height (mm)	Bolt Hole Dia. (mm)	Load Capacity (kg)	SWIVEL Part number	BRAKED Part number
50	20	70	M10	40	RT2BHAS/TPR	RT2BHBAS/TPR
75	32	100	M12	75	RT3BHAS/TPR	RT3BHBAS/TPR
100	32	134	M12	100	RT4BHAS/TPR	RT4BHBAS/TPR
125	32	159	M12	100	RT5BHAS/TPR	RT5BHBAS/TPR

Anti-static wheels

Anti-static materials are generally referred to as any material which inhibits triboelectric charging. This kind of charging is the buildup of an electric charge by the rubbing or contact with another material. Our castors have a 'conductive resistance' of less than 1×10^4 ohms.

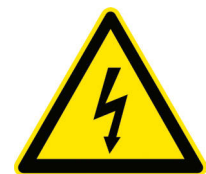

Tubular Fittings



M12-M10 Reducer

Light Duty Pressed Steel: Anti Static

50mm - 125mm diameter wheel | 40kg - 100kg load capacity



- Pressed steel bracket, zinc plated
- Swivel head with double ball race
- Anti-static, non marking grey TPR tyre, complete with threadguards
- Plain bore (50-100 mm), Ball bearing (125 mm)
- Wheel brake (50 mm), Swivel and wheel brake (75-125 mm)

Plate fitting

Wheel Dia. (mm)	Tread Width (mm)	Overall Height (mm)	Plate Size (mm)	Hole Centres (mm)	Load Capacity (kg)	SWIVEL Part number	BRAKED Part number
50	20	72	50 X 50	$\frac{40 \times 40}{32 \times 32}$	40	RT2PAS/TPR	RT2PBAS/TPR
75	32	103	105 X 80	$\frac{80 \times 60}{76 \times 44.5}$	75	RT3PAS/TPR	RT3PBAS/TPR
100	32	137	105 X 80	$\frac{80 \times 60}{76 \times 44.5}$	100	RT4PAS/TPR	RT4PBAS/TPR
125	32	162	105 X 80	$\frac{80 \times 60}{76 \times 44.5}$	100	RT5PAS/TPR	RT5PBAS/TPR

Castor mounting plates have slotted hole centres.

Anti-static wheels

Anti-static materials are generally referred to as any material which inhibits triboelectric charging. This kind of charging is the buildup of an electric charge by the rubbing or contact with another material.

Our castors have a 'conductive resistance' of less than 1×10^4 ohms.



Medium Duty Pressed Steel: Anti Static

100mm - 125mm diameter wheel | 125kg load capacity



- Pressed steel bracket, zinc plated
- Swivel head with double ball race
- Anti-static, non marking grey polyurethane tyre, complete with grey plastic threadguards

- Ball bearing
- Combined swivel and wheel brake



Bolt hole fitting

Wheel Dia. (mm)	Tread Width (mm)	Overall Height (mm)	Bolt Hole Dia. (mm)	Load Capacity (kg)	SWIVEL Part number	BRAKED Part number
100	32	134	M12	125	RT4A-BHAS	RT4A-BHBAS
125	32	159	M12	125	RT5A-BHAS	RT5A-BHBAS

Anti-static wheels

Anti-static materials are generally referred to as any material which inhibits triboelectric charging. This kind of charging is the buildup of an electric charge by the rubbing or contact with another material. Our castors have a 'conductive resistance' of less than 1×10^4 ohms.



Tubular Fittings



M12-M10 Reducer

Medium Duty Pressed Steel: Anti Static

100mm - 125mm diameter wheel | 125kg load capacity



- Pressed steel bracket, zinc plated
- Swivel head with double ball race
- Anti-static, non marking grey polyurethane tyre, complete with grey plastic threadguards

- Ball bearing
- Combined swivel and wheel brake

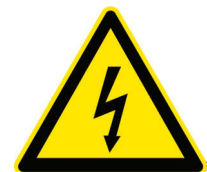

Plate fitting

Wheel Dia. (mm)	Tread Width (mm)	Overall Height (mm)	Plate Size (mm)	Hole Centres (mm)	Load Capacity (kg)	SWIVEL Part number	BRAKED Part number
100	32	137	105 X 80	$\frac{80 \times 60}{76 \times 44.5}$	125	RT4A-PAS	RT4A-PBAS
125	32	162	105 X 80	$\frac{80 \times 60}{76 \times 44.5}$	125	RT5A-PAS	RT5A-PBAS

Anti-static wheels

Anti-static materials are generally referred to as any material which inhibits triboelectric charging. This kind of charging is the buildup of an electric charge by the rubbing or contact with another material. Our castors have a 'conductive resistance' of less than 1×10^4 ohms.



Heavy Duty Pressed Steel: Anti Static

80mm - 200mm diameter wheel | 130kg - 400kg load capacity



- Pressed steel bracket, zinc plated
- Swivel head with double ball race
- Anti-static, non marking grey polyurethane tyre, complete with grey plastic threadguards

- Ball bearing
- Combined swivel and wheel brake



Bolt hole fitting

Wheel Dia. (mm)	Tread Width (mm)	Overall Height (mm)	Bolt Hole Dia. (mm)	Load Capacity (kg)	SWIVEL Part number	BRAKED Part number
80	32	99	M12	130	RT3LBHAS	RT3LBHBAS
100	32	124	M12	150	RT4LBHAS	RT4LBHBAS
125	32	154	M12	160	RT5LBHAS	RT5LBHBAS
160	46	185	M16	400	RT6LBHAS	RT6LBHBAS
200	50	230	M16	400	RT8LBHAS	RT8LBHBAS

Anti-static wheels

Anti-static materials are generally referred to as any material which inhibits triboelectric charging. This kind of charging is the buildup of an electric charge by the rubbing or contact with another material. Our castors have a 'conductive resistance' of less than 1×10^4 ohms.

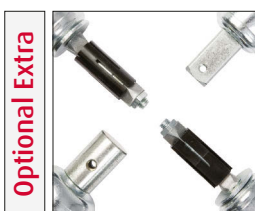
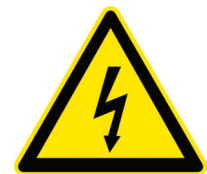

Tubular Fittings



M12-M10 Reducer
M16-M12 Reducer

Heavy Duty Pressed Steel: Anti Static

80mm - 200mm diameter wheel | 130kg - 400kg load capacity



- Pressed steel bracket, zinc plated
- Swivel head with double ball race
- Anti-static, non marking grey polyurethane tyre, complete with grey plastic threadguards
- Ball bearing
- Combined swivel and wheel brake



Plate fitting

Wheel Dia. (mm)	Tread Width (mm)	Overall Height (mm)	Plate Size (mm)	Hole Centres (mm)	Load Capacity (kg)	SWIVEL Part number	BRAKED Part number	FIXED Part number
80	32	100	105 X 80	80 X 60	130	RT3LPAS	RT3LPBAS	RT3LFPAS
100	32	125	105 X 80	80 X 60	150	RT4LPAS	RT4LPBAS	RT4LFPAS
125	32	155	105 X 80	80 X 60	160	RT5LPAS	RT5LPBAS	RT5LFPAS
160	46	190	135 X 110	105 X 80	400	RT6LPAS	RT6LPBAS	RT6LFPAS
200	50	235	135 X 110	105 X 80	400	RT8LPAS	RT8LPBAS	RT8LFPAS

Anti-static wheels

Anti-static materials are generally referred to as any material which inhibits triboelectric charging. This kind of charging is the buildup of an electric charge by the rubbing or contact with another material. Our castors have a 'conductive resistance' of less than 1×10^4 ohms.



Optional Extra



*Directional Lock
Available on 160 and
200mm castors.*

Plastic Castors

100mm - 200mm diameter wheel | 100kg - 120kg load capacity



- Moulded fibre glass polyamide housing
- Swivel head with water proof precision ball bearings
- Grey non-marking polyurethane tyre, nylon centre, ball bearing (Anti-static option) complete with grey plastic threadguards

- Captivated M10x20 threaded stem (Other options available)



Standard Wheel

Wheel Dia. (mm)	Tread Width (mm)	Overall Height (mm)	Bolt Fixing	Load Capacity (kg)	SWIVEL Part number	BRAKED Part number
100	32	145	M10x20	100	RT4P-PLAST	RT4PB-PLAST
125	32	165	M10x20	100	RT5P-PLAST	RT5PB-PLAST
150	32	195	M10x20	120	RT6P-PLAST	RT6PB-PLAST
200	32	251	M10x20	120	RT8P-PLAST	RT8PB-PLAST

Anti-static Wheel

Wheel Dia. (mm)	Tread Width (mm)	Overall Height (mm)	Bolt Fixing	Load Capacity (kg)	SWIVEL Part number	BRAKED Part number
100	32	145	M10x20	100	RT4PAS-PLAST	RT4PBAS-PLAST
125	32	165	M10x20	100	RT5PAS-PLAST	RT5PBAS-PLAST
150	32	195	M10x20	120	RT6PAS-PLAST	RT6PBAS-PLAST
200	32	251	M10x20	120	RT8PAS-PLAST	RT8PBAS-PLAST

Optional Extra



Expanders and Stems

High Temperature Castors

100mm diameter wheel | 125kg load capacity

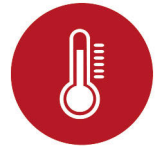

- Pressed steel bracket, zinc plated
- Swivel head with double ball race
- Black phenolic wheel
- Plain bore with Teflon axle bush
- Temperature range: -40°C to +280°C

Bolt hole fitting

Wheel Dia. (mm)	Tread Width (mm)	Overall Height (mm)	Bolt Hole Dia. (mm)	Load Capacity (kg)	SWIVEL Part number
100	34	127	12	125	RT4-DLBH-PHHT

Plate fitting

Wheel Dia. (mm)	Tread Width (mm)	Overall Height (mm)	Plate Size (mm)	Hole Centres (mm)	Load Capacity (kg)	SWIVEL Part number	FIXED Part number
100	34	128	105 X 85	80 X 60	125	RT4-DLP-PHHT	RT4-DLFP-PHHT

Heavy Duty Pressed Steel: Composite/ Sandwich

100mm diameter wheel | 200kg load capacity



- Heavy duty pressed steel bracket, zinc plated
- Swivel head with double ball race
- Composite, roller bearing wheel
- Supplied complete with threadguards
- Operating temperature range: -30°C to +50°C

- Polymer wheel hub and tyre, thermoplastic rubber infill
- Wheel Colour - Grey with red infill as standard, other colours available for minimum quantities
- Threadguards - Standard colours: Green (swivel), Red (fixed)



Plate fitting

Wheel Dia. (mm)	Tread Width (mm)	Overall Height (mm)	Plate Size (mm)	Hole Centres (mm)	Load Capacity (kg)	SWIVEL Part number	FIXED Part number
100	35	128	105 X 85	80 X 60	200	RT4VVPSW	N/A
100	35	128	99 X 78.5	$\frac{76 \times 80}{44.5 \times 60}$	200	N/A	RT4VVFPSW

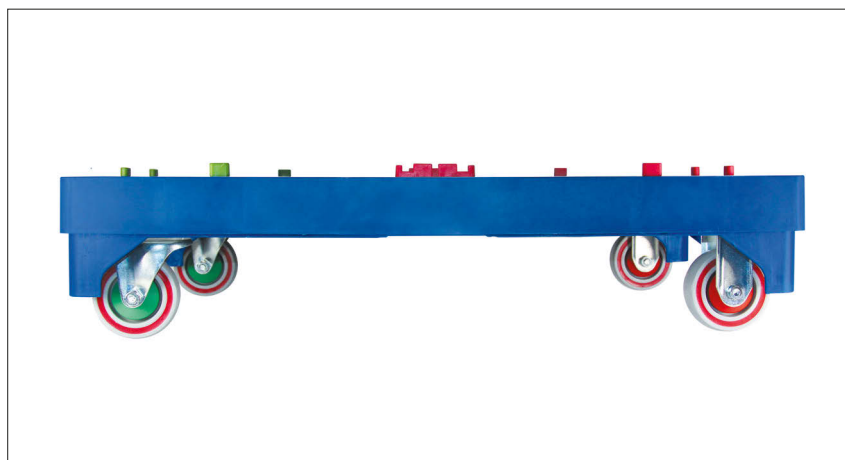

Heavy Duty Pressed Steel: Composite/ Sandwich

125mm diameter wheel | 200kg load capacity



- Heavy duty pressed steel bracket, zinc plated
- Swivel head with double ball race
- Composite, roller bearing wheel
- Supplied complete with threadguards
- Operating temperature range: -30°C to +50°C
- Polymer wheel hub and tyre, thermoplastic rubber infill
- Wheel Colour - Grey with red infill as standard, other colours available for minimum quantities
- Threadguards - Standard colours: Green (swivel and braked swivel), Red (fixed)



Plate fitting

Wheel Dia. (mm)	Overall Height (mm)	Plate Size (mm)	Hole Centres (mm)	Swivel Radius (mm)	Load Capacity (kg)	SWIVEL Part number	FIXED Part number
125	154	105 X 80	80 X 60	93	200	RT5/SWC-SWIVEL	RT5/SWC-FIXED



Bolt hole housings and brake options available.

Medium Duty Pressed Steel: Microcellular

260mm diameter wheel | 120kg load capacity

Solid puncture proof tyre with the benefits of a pneumatic wheel.

LIGHT TREAD PATTERN



- Pressed steel bracket, zinc plated
- Swivel head with double ball race
- Black microcellular polyurethane tyre, light tread pattern with red plastic centre
- Roller bearing



Plate fitting

Wheel Dia. (mm)	Tread Width (mm)	Overall Height (mm)	Plate Size (mm)	Hole Centres (mm)	Load Capacity (kg)	SWIVEL Part number	FIXED Part number
260	75	295	175 X 175	140 X 140	120	RT10LP-LIGHTP-MCP-RB	N/A
260	75	295	230 X 125	190 X 75	120	N/A	RT10LFP-LIGHTP-MCP-RB

Medium Duty Pressed Steel: Microcellular

260mm diameter wheel | 120kg load capacity

Solid puncture proof tyre with the benefits of a pneumatic wheel.

HEAVY TREAD PATTERN



- Pressed steel bracket, zinc plated
- Swivel head with double ball race
- Black microcellular polyurethane tyre, heavy tread pattern with red plastic centre
- Roller bearing



Plate fitting

Wheel Dia. (mm)	Tread Width (mm)	Overall Height (mm)	Plate Size (mm)	Hole Centres (mm)	Load Capacity (kg)	SWIVEL Part number	FIXED Part number
260	85	295	175 X 175	140 X 140	120	RT10LPMCP-RB	N/A
260	85	295	230 X 125	190 X 75	120	N/A	RT10LFPMCP-RB

Medium Duty Pressed Steel: Microcellular

260mm diameter wheel | 120kg load capacity

Solid puncture proof tyre with the benefits of a pneumatic wheel.

LIGHT TREAD PATTERN



- Fabricated steel bracket (Zinc plated)
- Swivel head with double ball race
- Black microcellular polyurethane tyre, light tread pattern with red plastic centre
- Roller bearing



Plate fitting

Wheel Dia. (mm)	Tread Width (mm)	Overall Height (mm)	Plate Size (mm)	Hole Centres (mm)	Load Capacity (kg)	SWIVEL Part number	FIXED Part number
260	75	300	92 X 68 77 X 76	92 X 68	120	632266/PP	632266/FXD/PP

Medium Duty Pressed Steel: Microcellular

260mm diameter wheel | 120kg load capacity

Solid puncture proof tyre with the benefits of a pneumatic wheel.

HEAVY TREAD PATTERN



- Fabricated steel bracket (Zinc plated)
- Swivel head with double ball race
- Black microcellular polyurethane tyre, heavy tread pattern with red plastic centre
- Roller bearing



Plate fitting

Wheel Dia. (mm)	Tread Width (mm)	Overall Height (mm)	Plate Size (mm)	Hole Centres (mm)	Load Capacity (kg)	SWIVEL Part number	FIXED Part number
260	75	300	114 X 100	$\frac{92 \times 68}{77 \times 76}$	120	632266/MCP	632266/FXD/MCP

WHEELS



Rubber Tyred Wheels

80mm - 200mm diameter wheels | 60kg - 205kg capacity

Black solid rubber tyre | Polypropylene centre



Wheel Dia. (mm)	Tread Width (mm)	Bearing type	Bore (mm)	Hub Length (mm)	Load Capacity (kg)	PART NUMBER
80	31/22	RB	12	40	60	RT3BP-M12RB
100	31/24	RB	12	40	75	RT4BP-M12RB
125	38/25	RB	15	50	100	RT5BP-M15RB



Wheel Dia. (mm)	Tread Width (mm)	Bearing type	Bore (mm)	Hub Length (mm)	Load Capacity (kg)	PART NUMBER
160	41/21	RB	20	60	135	RT6BP-M20RB
200	48/30	RB	20	60	205	RT8BP-M20RB

Black solid rubber tyre | Steel centre



Wheel Dia. (mm)	Tread Width (mm)	Bearing type	Bore (mm)	Hub Length (mm)	Load Capacity (kg)	PART NUMBER
80	28/20	RB	12	40	60	RT3BM-M12RB
100	30/21	RB	12	40	75	RT4BM-M12RB
125	36/25	RB	15	50	100	RT5BM-M15RB
160	38/25	RB	20	60	135	RT6BM-M20RB
200	45/30	RB	20	60	205	RT8BM-M20RB

Grey solid rubber tyre | Plastic centre



Wheel Dia. (mm)	Tread Width (mm)	Bearing type	Bore (mm)	Hub Length (mm)	Load Capacity (kg)	PART NUMBER
80	31/22	RB	12	40	60	RT3GP-M12RB
100	31/24	RB	12	40	75	RT4GP-M12RB
125	38/25	RB	15	50	100	RT5GP-M15RB
160	41/21	RB	20	60	135	RT6GP-M20RB
200	48/30	RB	20	60	205	RT8GP-M20RB

Rubber Tyred Wheels

75mm - 200mm diameter wheels | 75kg - 400kg capacity

Grey Thermoplastic Rubber Tyre | Nylon Centre | Metal threaguards, Axle Bush, M8 Nut and Bolt



Wheel Dia. (mm)	Tread Width (mm)	Bearing type	Bore (mm)	Hub Length (mm)	Load Capacity (kg)	PART NUMBER
75	32	PB	8	35	75	RT3AGREY-PB/ASS
100	32	PB	8	35	100	RT4AGREY-PB/ASS
125	32	PB	8	35	100	RT5AGREY-PB/ASS

Grey Thermoplastic Rubber Tyre | Nylon Centre | Plastic integral threaguards, M8 Nut and Bolt



Wheel Dia. (mm)	Tread Width (mm)	Bearing type	Bore (mm)	Hub Length (mm)	Load Capacity (kg)	PART NUMBER
100	32	BB	8	35	100	RT4AGREY-BB/ASS
125	32	BB	8	35	100	RT5AGREY-BB/ASS

Blue elastic rubber tyre | Nylon centre



Wheel Dia. (mm)	Tread Width (mm)	Bearing type	Bore (mm)	Hub Length (mm)	Load Capacity (kg)	PART NUMBER
80	34/23	RB	12	40	150	RT3BLU
100	35/25	RB	12	40	200	RT4BLU
125	35/25	RB	15	50	200	RT5BLU
160	45/41	RB	20	60	350	RT6BLU
200	45/38	RB	20	60	400	RT8BLU

Black elastic rubber tyre | Nylon centre



Wheel Dia. (mm)	Tread Width (mm)	Bearing type	Bore (mm)	Hub Length (mm)	Load Capacity (kg)	PART NUMBER
80	34/23	RB	12	40	150	RT3BLK
100	35/25	RB	12	40	200	RT4BLK
125	35/25	RB	15	50	200	RT5BLK
160	45/41	RB	20	60	350	RT6BLK
200	45/38	RB	20	60	400	RT8BLK

Rubber Tyred Wheels

100mm - 300mm diameter wheels | 200kg - 800kg capacity

Black elastic rubber tyre | Aluminium centre



Wheel Dia. (mm)	Tread Width (mm)	Bearing type	Bore (mm)	Hub Length (mm)	Load Capacity (kg)	PART NUMBER
100	39/29	BB	12	40	200	RT4ALUBLK-BBM12
125	39/29	BB	15	40	250	RT5ALUBLK-BBM15



Wheel Dia. (mm)	Tread Width (mm)	Bearing type	Bore (mm)	Hub Length (mm)	Load Capacity (kg)	PART NUMBER
160	50/38	BB	20	60	350	RT6ALUBLK-BBM20
200	50/38	BB	20	60	450	RT8ALUBLK-BBM20
250	50/38	BB	20	60	650	RT10ALUBLK-BBM20

Grey elastic rubber tyre | Aluminium centre



Wheel Dia. (mm)	Tread Width (mm)	Bearing type	Bore (mm)	Hub Length (mm)	Load Capacity (kg)	PART NUMBER
160	50/38	BB	20	60	350	RT6ALUGRY-BBM20
200	50/38	BB	20	60	450	RT8ALUGRY-BBM20

Black elastic rubber tyre | Cast iron centre



Wheel Dia. (mm)	Tread Width (mm)	Bearing type	Bore (mm)	Hub Length (mm)	Load Capacity (kg)	PART NUMBER
100	50/44	BB	20	60	210	RT4CIBLK-BBM20
100	50/44	BB	25	60	210	RT4CIBLK-BBM25
125	50/44	BB	20	60	275	RT5CIBLK-BBM20
125	50/44	BB	25	60	275	RT5CIBLK-BBM25
150	50/43	BB	20	60	400	RT6CIBLK-BBM20
150	50/43	BB	25	60	400	RT6CIBLK-BBM25
200	50/46	BB	20	60	600	RT8CIBLK-BBM20
200	50/46	BB	25	60	600	RT8CIBLK-BBM25
250	50/46	BB	20	60	700	RT10CIBLK-BBM20
250	50/46	BB	25	60	700	RT10CIBLK-BBM25
300	50/46	BB	20	60	800	RT12CIBLK-BBM20
300	50/46	BB	25	60	800	RT12CIBLK-BBM25

Polyurethane Tyred Wheels

80mm - 200mm diameter wheels | 100kg - 800kg capacity

Red polyurethane tyre | White nylon centre



Wheel Dia. (mm)	Tread Width (mm)	Bearing type	Bore (mm)	Hub Length (mm)	Load Capacity (kg)	PART NUMBER
80	30	RB	12	40	100	PU08012040
100	35	PB	12	35	220	PU10012035
100	35	PB	12	39	220	PU10012039
100	35	RB	12	40	220	PU10020040/CWB
125	35	PB	15	47	300	PU12515047
125	35	RB	15	47	300	PU12523047/CWB

Red polyurethane tyre | Grey nylon centre



Wheel Dia. (mm)	Tread Width (mm)	Bearing type	Bore (mm)	Hub Length (mm)	Load Capacity (kg)	PART NUMBER
150	50	RB	20	60	350	PU150RD-RB-HD
200	50	RB	20	60	400	PU200RD-RB-HD

Polyurethane tyre | Black glass filled nylon centre



Wheel Dia. (mm)	Tread Width (mm)	Bearing type	Bore (mm)	Hub Length (mm)	Load Capacity (kg)	PART NUMBER
125	46	BB	12	60	450	DK125BB
160	46	BB	12	60	650	DK160BB
200	50	BB	12	60	800	DK200BB

Polyurethane Tyred Wheels

100mm - 300mm diameter wheels | 225kg - 2200kg capacity

Polyurethane tyre | Aluminium centre



Wheel Dia. (mm)	Tread Width (mm)	Bearing type	Bore (mm)	Hub Length (mm)	Load Capacity (kg)	PART NUMBER
100	30	BB	12	41	225	RT4PUALU-BBM12
125	30	BB	15	47	275	RT5PUALU-BBM15
160	50	BB	20	60	600	RT6PUALU-BBM20
200	50	BB	20	60	800	RT8PUALU-BBM20

Polyurethane tyre | Cast iron centre



Wheel Dia. (mm)	Tread Width (mm)	Bearing type	Bore (mm)	Hub Length (mm)	Load Capacity (kg)	PART NUMBER
100	30	BB	12	41	250	RT4CIPU-BBM12
125	30	BB	15	47	300	RT5CIPU-BBM15



Wheel Dia. (mm)	Tread Width (mm)	Bearing type	Bore (mm)	Hub Length (mm)	Load Capacity (kg)	PART NUMBER
100	50	BB	20	60	450	RT4CIPU-BBM20
125	50	BB	20	60	550	RT5CIPU-BBM20
150	50	BB	20	60	800	RT6CIPU-BBM20
200	50	BB	20	60	1000	RT8CIPU-BBM20
250	50	BB	20	60	1300	RT10CIPU-BBM20
250	50	BB	25	60	1300	RT10CIPU-BBM25
300	75	BB	20	82	2200	RT12CIPU-BBM20
300	75	BB	25	82	2200	RT12CIPU-BBM25

Polypropylene & Nylon Wheels

75mm - 200mm diameter wheels | 70kg - 1200kg load capacity

White polypropylene wheel



Wheel Dia. (mm)	Tread Width (mm)	Bearing type	Bore (mm)	Hub Length (mm)	Load Capacity (kg)	PART NUMBER
75	25	PB	12	35	70	PP07512035
100	32	PB	12	35	125	PP10012035
100	32	PB	12	39	125	PP10012039
125	35	PB	12	35	125	PP12512035

Nylon wheel



Wheel Dia. (mm)	Tread Width (mm)	Bearing type	Bore (mm)	Hub Length (mm)	Load Capacity (kg)	PART NUMBER
75	25	PB	12	40	170	NY07512040
80	25	PB	12	40	170	NY08012040
100	32	PB	12	35	200	NY10012035
100	32	PB	12	39	250	NY10012039
100	32	RB	12	40	250	NY10020040/CWB
125	35	PB	12	35	200	NY12512039
125	35	PB	15	47	300	NY12515047
125	35	RB	15	47	300	NY12523047/CWB
160	40	PB	20	58	400	NY16020058
160	40	RB	20	58	400	NY16020058-RB
200	50	PB	20	58	600	NY20020058
200	50	RB	20	58	600	NY20020058-RB

Nylon tyre | Black glass filled nylon centre



Wheel Dia. (mm)	Tread Width (mm)	Bearing type	Bore (mm)	Hub Length (mm)	Load Capacity (kg)	PART NUMBER
125	46	BB	12	60	700	NKS125X46
160	46	BB	12	60	900	NKS160X46
200	50	BB	12	60	1200	NKS200X50

Cast Iron, Phenolic & Anti-Static Wheels

100mm - 250mm diameter wheels | 125kg - 1500kg load capacity

Cast iron wheel



Wheel Dia. (mm)	Tread Width (mm)	Bearing type	Bore (mm)	Hub Length (mm)	Load Capacity (kg)	PART NUMBER
100	50	BB	20	60	450	RT4CI-BBM20
125	40	BB	20	60	650	RT5CI-BBM20
150	45	BB	20	60	900	RT6CI-BBM20
200	45	BB	20	60	1100	RT8CI-BBM20
200	45	BB	25	60	1100	RT8CI-BBM25
250	50	BB	20	60	1500	RT10CI-BBM20
250	50	BB	25	60	1500	RT10CI-BBM25

High temperature phenolic wheel



Wheel Dia. (mm)	Tread Width (mm)	Bearing type	Bore (mm)	Hub Length (mm)	Load Capacity (kg)	PART NUMBER
100	35	PB	12	40	125	RT4PHHT

Suitable for use in temperatures -40°C to +280°C

Anti-static non-marking polyurethane wheel



Wheel Dia. (mm)	Tread Width (mm)	Bearing type	Bore (mm)	Hub Length (mm)	Load Capacity (kg)	PART NUMBER
80	32	BB	8	39	130	DHS080X32
100	32	BB	8	39	150	DHS100X32
125	32	BB	8	39	160	DHS125X32
160	46	BB	20	60	450	DHS160X46
200	50	BB	20	60	500	DHS200X50

Microcellular Wheels

260mm diameter | 120kg load capacity



Heavy tread pattern



Light tread pattern

Solid puncture proof tyre with the benefits of a pneumatic wheel

- 260mm diameter
- Black microcellular polyurethane tyre
- Red plastic centre
- Roller bearing bore

Heavy tread pattern

Wheel Dia. (mm)	Tyre Width (mm)	Bearing Type	Bore Dia. (mm)	Hub Length (mm)	Load Cap. (kg)	Weight (kg)	PART NUMBER
260	85	Roller	20	75	120	1.5	RTPWR260PP2075RED
260	85	Roller	25	75	120	1.5	RTPWR260PP2575RED

Light tread pattern

Wheel Dia. (mm)	Tyre Width (mm)	Bearing Type	Bore Dia. (mm)	Hub Length (mm)	Load Cap. (kg)	Weight (kg)	PART NUMBER
260	75	Roller	20	75	120	1.5	MCP260PP2075RED

Other wheels and sizes available. Please call our sales department for assistance.

Manutal Range: Solid black rubber tyre, plastic centre wheels

160mm - 300mm diameter | 175kg - 250kg load capacity



Solid black rubber tyre | Plastic centre wheels

Wheel Dia. (mm)	Tyre Width (mm)	Bearing Type	Bore Dia. (mm)	Hub Length (mm)	Load Cap. (kg)	Weight (kg)	PART NUMBER	
							RED CENTRE	BLACK CENTRE
160	41	Plain	25.4 (1")	51	175	0.7	N/A	6711622610
200	50	Plain	20	51	200	1.2	6712012000	N/A
200	50	Plain	25.4 (1")	51	200	1.2	6712012600	6712012610
200	50	Roller	25.4 (1")	51	200	1.3	6722012600	N/A
250	50	Plain	25.4 (1")	51	250	2.0	6712502600	N/A
275	50	Plain	25.4 (1")	51	250	2.1	6712752600	N/A
300	50	Plain	25.4 (1")	60	250	2.3	N/A	6163022610

Other wheels and sizes available. Please call our sales department for assistance.

Industrial Wheel: Solid black rubber tyre, plastic centre wheels

200mm diameter | 250kg load capacity



Solid rubber tyre | Plastic centre

Wheel Dia. (mm)	Tyre Width (mm)	Bearing Type	Bore Dia. (mm)	Hub Length (mm)	Load Cap. (kg)	Weight (kg)	PART NUMBER
200	76	Plain	20	76	250	2.2	RTPW200/20/75RED
200	76	Roller	20	76	250	2.2	RTPWR200/20/75RED
200	76	Plain	25	76	250	2.2	RTPW200/25/75RED
200	76	Roller	25	76	250	2.2	RTPWR200/25/75RED
200	76	Plain	25.4 (1")	76	250	2.2	RTPW200/25.4/75RED
200	76	Roller	25.4 (1")	76	250	2.2	RTPWR200/25.4/75RED

Other wheels and sizes available. Please call our sales department for assistance.

Industrial Wheel: Solid black rubber tyre, plastic centre wheels

280mm - 400mm diameter | 250kg - 350kg load capacity



Solid rubber tyre | Plastic centre

Wheel Dia. (mm)	Tyre Width (mm)	Bearing Type	Bore Dia. (mm)	Hub Length (mm)	Load Cap. (kg)	Weight (kg)	PART NUMBER
280	80	Plain	20	66	250	3.4	RTPW280/20/66RED
280	80	Roller	20	66	250	3.4	RTPWR280/20/66RED
280	80	Plain	25	66	250	3.4	RTPW280/25/66RED
280	80	Roller	25	66	250	3.4	RTPWR280/25/66RED
280	80	Plain	25.4 (1")	66	250	3.4	RTPW280/25.4/66RED
280	80	Roller	25.4 (1")	66	250	3.4	RTPWR280/25.4/66RED
330	70	Plain	20	66	250	4.5	RTPW330/20/66RED
330	70	Roller	20	66	250	4.5	RTPWR330/20/66RED
330	70	Plain	25	66	250	4.5	RTPW330/25/66RED
330	70	Roller	25	66	250	4.5	RTPWR330/25/66RED
330	70	Plain	25.4 (1")	66	250	4.5	RTPW330/25.4/66RED
330	70	Roller	25.4 (1")	66	250	4.5	RTPWR330/25.4/66RED
355	75	Plain	20	66	300	6.5	RTPW355/20/66RED
355	75	Roller	20	66	300	6.5	RTPWR355/20/66RED
355	75	Plain	25	66	300	6.5	RTPW355/25/66RED
355	75	Roller	25	66	300	6.5	RTPWR355/25/66RED
355	75	Plain	25.4 (1")	66	300	6.5	RTPW355/25.4/66RED
355	75	Roller	25.4 (1")	66	300	6.5	RTPWR355/25.4/66RED
400	90	Plain	20	66	350	10	RTPW400/20/66RED
400	90	Roller	20	66	350	10	RTPWR400/20/66RED
400	90	Plain	25	66	350	10	RTPW400/25/66RED
400	90	Roller	25	66	350	10	RTPWR400/25/66RED
400	90	Plain	25.4 (1")	66	350	10	RTPW400/25.4/66RED
400	90	Roller	25.4 (1")	66	350	10	RTPWR400/25.4/66RED

Other wheels and sizes available. Please call our sales department for assistance.

Industrial Wheel: Solid black rubber tyre, metal centre wheels

280mm - 330mm diameter | 250kg - 300kg load capacity



280 WHEEL



330 WHEEL

Solid rubber tyre | Metal centre

Wheel Dia. (mm)	Tyre Width (mm)	Bearing Type	Bore Dia. (mm)	Hub Length (mm)	Load Cap. (kg)	Weight (kg)	PART NUMBER
280	80	Plain	20	68	250	3.4	RTMG280/20/70RED
280	80	Roller	20	68	250	3.4	RTMR280/20/66RED
280	80	Plain	25	68	250	3.4	RTMG280/25/70RED
280	80	Roller	25	68	250	3.4	RTMR280/25/66RED
280	80	Plain	25.4 (1")	68	250	3.4	RTMG280/25.4/70RED
280	80	Roller	25.4 (1")	68	250	3.4	RTMR280/25.4/66RED
330	70	Plain	20	68	300	4.5	RTMG330/20/70RED
330	70	Roller	20	68	300	4.5	RTMR330/20/66RED
330	70	Plain	25	68	300	4.5	RTMG330/25/70RED
330	70	Roller	25	68	300	4.5	RTMR330/25/66RED
330	70	Plain	25.4 (1")	68	300	4.5	RTMG330/25.4/70RED
330	70	Roller	25.4 (1")	68	300	4.5	RTMR330/25.4/66RED

Other wheels and sizes available. Please call our sales department for assistance.

Industrial Wheel: Solid black rubber tyre, metal centre wheels

355mm - 400mm diameter | 400kg load capacity



355 WHEEL



400 WHEEL

Solid rubber tyre | Metal centre

Wheel Dia. (mm)	Tyre Width (mm)	Bearing Type	Bore Dia. (mm)	Hub Length (mm)	Load Cap. (kg)	Weight (kg)	PART NUMBER
355	75	Plain	20	68	400	6.5	RTMG355/20/70RED
355	75	Roller	20	68	400	6.5	RTMR355/20/66RED
355	75	Plain	25	68	400	6.5	RTMG355/25/70RED
355	75	Roller	25	68	400	6.5	RTMR355/25/66RED
355	75	Plain	25.4 (1")	68	400	6.5	RTMG355/25.4/70RED
355	75	Roller	25.4 (1")	68	400	6.5	RTMR355/25.4/66RED
400	90	Plain	20	68	400	10	RTMG400/20/70RED
400	90	Roller	20	68	400	10	RTMR400/20/66RED
400	90	Plain	25	68	400	10	RTMG400/25/70RED
400	90	Roller	25	68	400	10	RTMR400/25/66RED
400	90	Plain	25.4 (1")	68	400	10	RTMG400/25.4/70RED
400	90	Roller	25.4 (1")	68	400	10	RTMR400/25.4/66RED

Other wheels and sizes available. Please call our sales department for assistance.



Castormart Limited
102 University Avenue
Belfast BT7 1GY
Northern Ireland

Tel: 028 9032 3263 | Fax: 028 9024 9784

belfast@castormart.com

www.castormart.com